



**EDUCATION  
PARTNER**

This Online Learning Seminar is available through a professional courtesy provided by:



CGC Group Inc.  
150 Britannia Road East, Unit #1  
Mississauga, ON L4Z 2A4  
Tel: (905) 568-1661  
Fax: (905) 568-2839  
Toll-Free: 1-888—220-5551  
Email: [rjg@cssi.ca](mailto:rjg@cssi.ca)  
Web: [www.cgc-group.com](http://www.cgc-group.com)

**START**

powered by  [www.aecdaily.com](http://www.aecdaily.com)

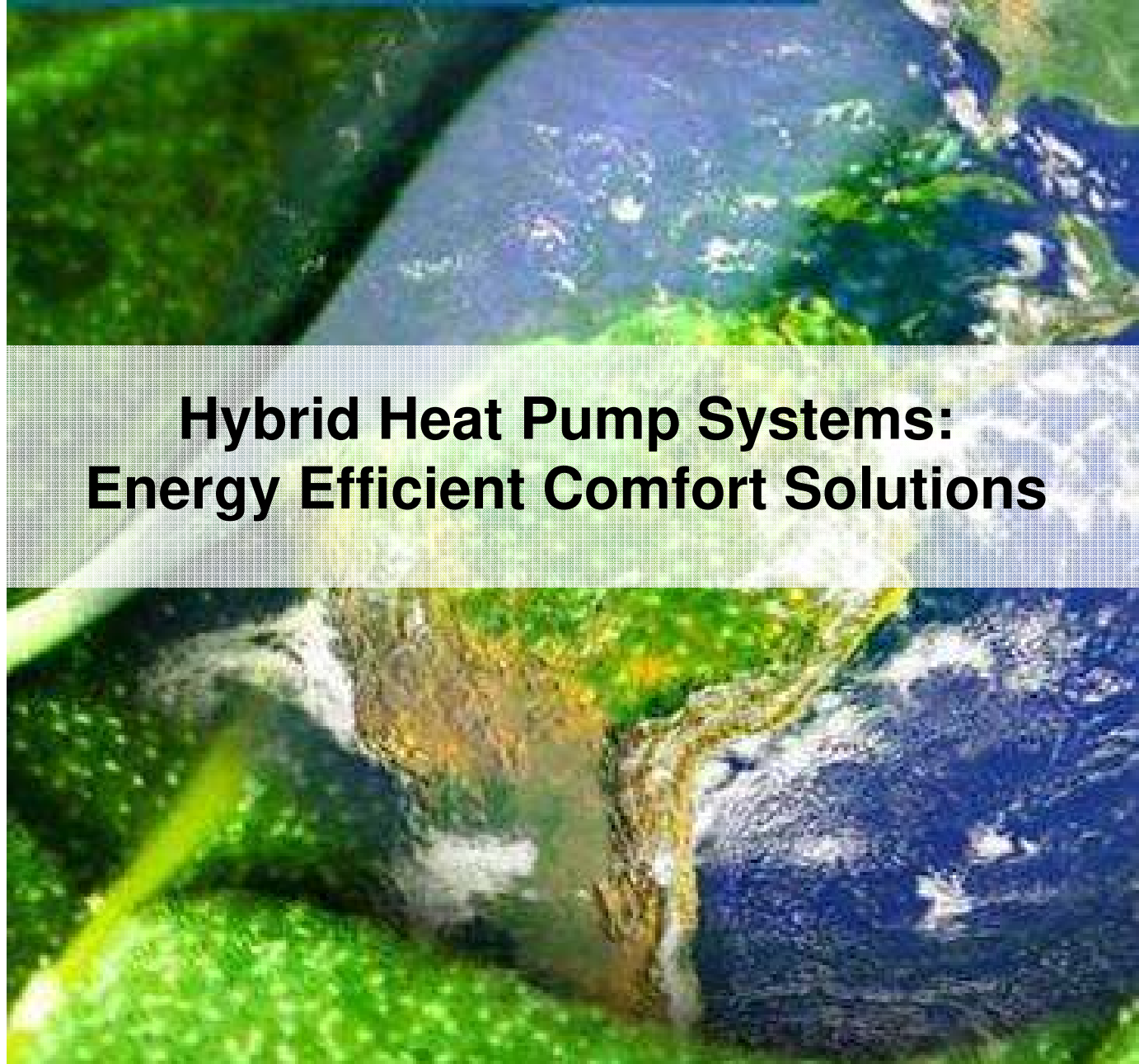

## Hybrid Heat Pump Systems: Energy Efficient Comfort Solutions

©2011, 2014 CGC Group Inc. The material contained in this course was researched, assembled, and produced by CGC Group Inc. and remains its property. “LEED” and related logo is a trademark owned by the U.S. Green Building Council and is used by permission. Questions or concerns about the content of this course should be directed to the program instructor. This multimedia product is the copyright of AEC Daily.

# Hybrid Heat Pump Systems: Energy Efficient Comfort Solutions

Presented By: CGC Group Inc.  
150 Britannia Road East, Unit #1  
Mississauga, ON L4Z 2A4

Description: Provides an overview of the operation of hybrid heat pump systems and hybrid heat pump geothermal systems, including their energy savings, low electrical consumption, and efficient use of reclaimed heat.

To ensure the accuracy of this program material, this course is valid only when listed on AEC Daily's Online Learning Center. Please [click here](#) to verify the status of this course.

If the course is not displayed on the above page, it is no longer offered.

---

**The American Institute of Architects · Course No. AEC475 · This program qualifies for 1.5 LU/HSW Hours.**



AEC Daily Corporation is a Registered Provider with The American Institute of Architects Continuing Education Systems (AIA/CES). Credit(s) earned on completion of this program will be reported to AIA/CES for AIA members. Certificates of Completion for both AIA members and non-AIA members are available upon request. This program is registered with AIA/CES for continuing professional education. As such, it does not include content that may be deemed or construed to be an approval or endorsement by the AIA of any material of construction or any method or manner of handling, using, distributing, or dealing in any material or product. Questions related to specific materials, methods, and services will be addressed at the conclusion of this presentation.

---

This course is approved by other organizations. Please [click here](#) for details.

# Learning Objectives

At the end of this program, participants will be able to:

- explain the operation of traditional reversing water source heat pump (WSHP) systems, hybrid heat pump systems, and hybrid heat pump geothermal systems
- explain how a hybrid heat pump system maximizes the design advantages and eliminates the design disadvantages of a traditional WSHP system
- identify the benefits of hybrid heat pump systems and hybrid heat pump geothermal systems in terms of their energy efficiency and cost savings
- detail how hybrid heat pump systems and hybrid heat pump geothermal systems not only conserve energy but also reclaim “waste” heat and use it for a wide variety of heating purposes throughout an entire building, and
- discuss how hybrid heat pump systems and hybrid heat pump geothermal systems provide occupants of a building with year-round comfort (heating or cooling), low sound levels, and dehumidification when required.

# How to Use This Online Learning Course

- To **view** this course, use the arrows at the bottom of each slide or the up and down arrow keys on your keyboard.
- To **print** or **exit** the course at any time, press the **ESC** key on your keyboard. This will minimize the full-screen presentation and display the menu bar.
- Within this course is an  **exam password** that you will be required to enter in order to proceed with the online examination. Please be sure to remember or write down this **exam password** so that you have it available for the test.
- To receive a **certificate** indicating course completion, refer to the instructions at the end of the course.
- For **additional information** and post-seminar assistance, click on any of the logos and icons within a page or any of the links at the top of each page.

# Table of Contents

Traditional Reversing WSHP Systems	6
Hybrid Heat Pump Systems	15
Heat Extraction & Recovery	27
Energy & Economics	37
Benefits of Hybrid Heat Pump Systems	55
Applications	63
Hybrid Heat Pump Geothermal Systems	69

Click on title to view



---

---

# Traditional Reversing WSHP Systems

---

---

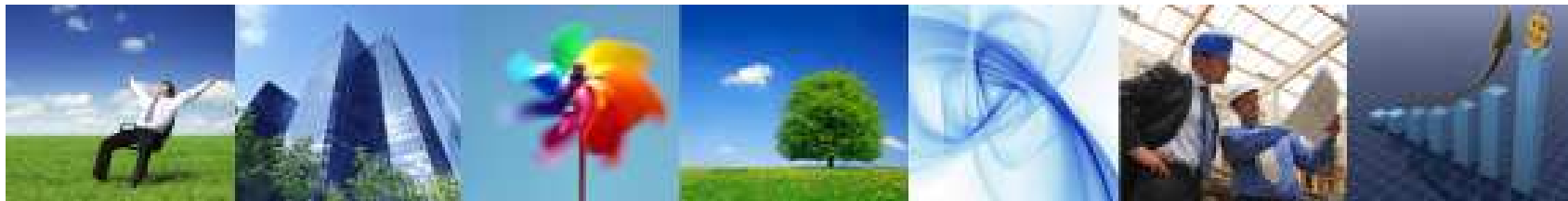

# Introduction

The fundamental driving force behind the development of the hybrid heat pump system was to maximize the benefits of the traditional water source heat pump (WSHP) system while eliminating the disadvantages.

In order to explain how the hybrid system works, it is important to first establish how a traditional reversing WSHP works.



# Traditional Reversing WSHP System

A traditional WSHP system consists of heat pumps that provide mechanical heating and cooling. The units are all connected to a common fluid loop. The cooling units reject the heat of compression to the fluid loop, whereas the heating units absorb the heat from the fluid loop.

Also on this fluid loop are fluid coolers, which expel excess heat into the atmosphere, and boilers, to inject heat whenever it is required. A WSHP system can either heat or cool at any time of the year depending on the need. One main feature of the system is its ability to move heat from cooling zones to heating zones, thereby making it an energy efficient system.

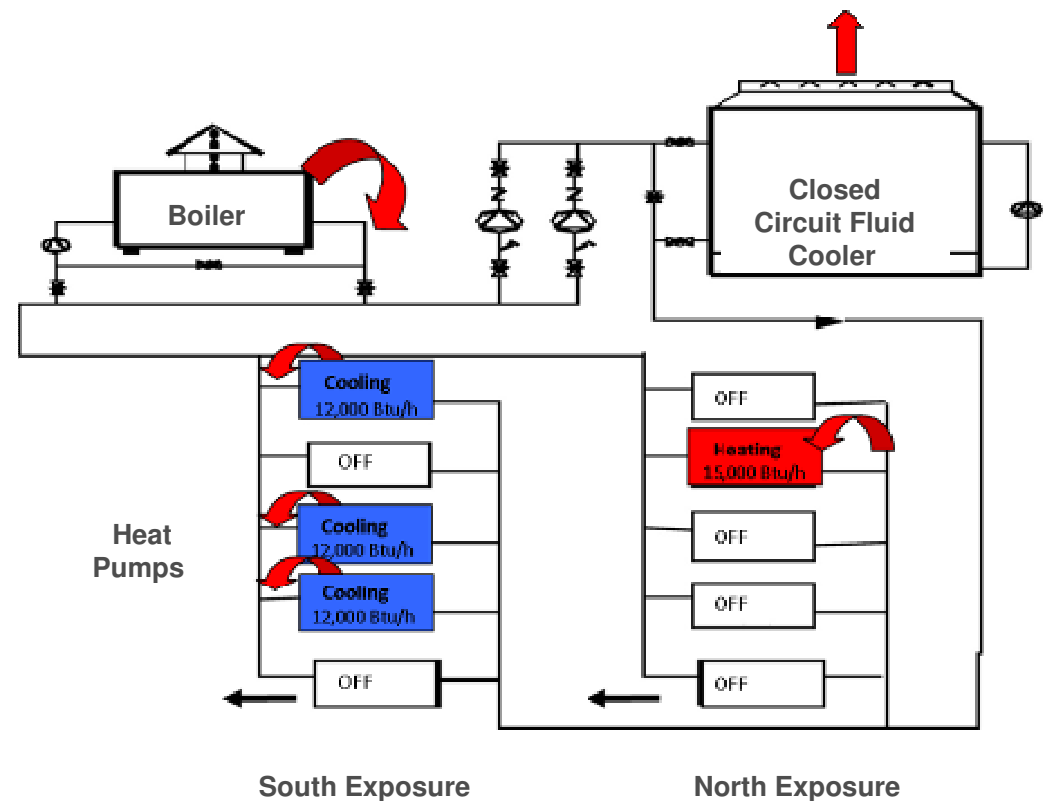



# WSHP Cooling Mode

A reversing WSHP system is basically a water cooled air conditioner. It has an air-to-refrigerant exchanger which functions as the evaporator in the cooling mode. Its function is to absorb heat from the air passing over this DX (direct-expansion) coil. The refrigerant gas evaporates as it absorbs the heat.

The gas is then compressed by the compressor, and the hot gas is transferred to the condenser, usually a coaxial exchanger, which gives up the heat to the fluid. The heat that resides in the fluid loop can be used by the heating units or rejected to the atmosphere through a fluid cooler. The reversing valve ensures the proper direction of the refrigerant.

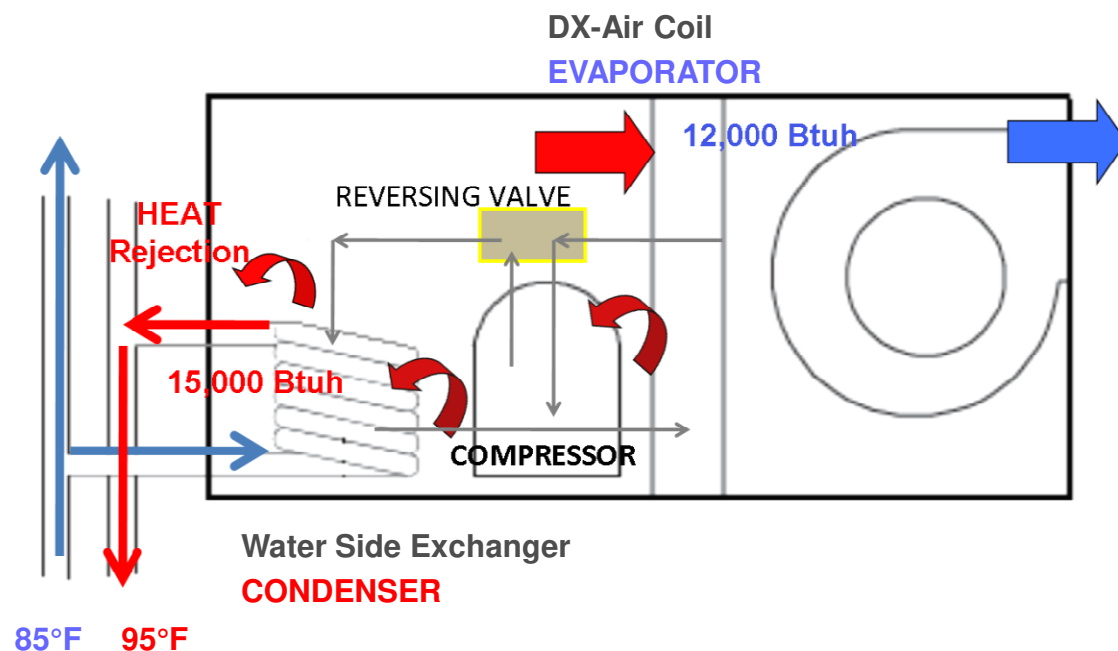

# WSHP Cooling Mode

Note, a one (1) ton unit will deliver approximately 12,000 Btuh of cooling through the evaporator (DX coil) and will reject approximately 15,000 Btuh of total heat through the condenser. The condenser rejects more heat than the evaporator absorbs, and therefore handles and requires more exchange capability. The condenser has to reject the heat absorbed from the air stream plus the heat of compression. This is normal in any water cooled unit or chillers.

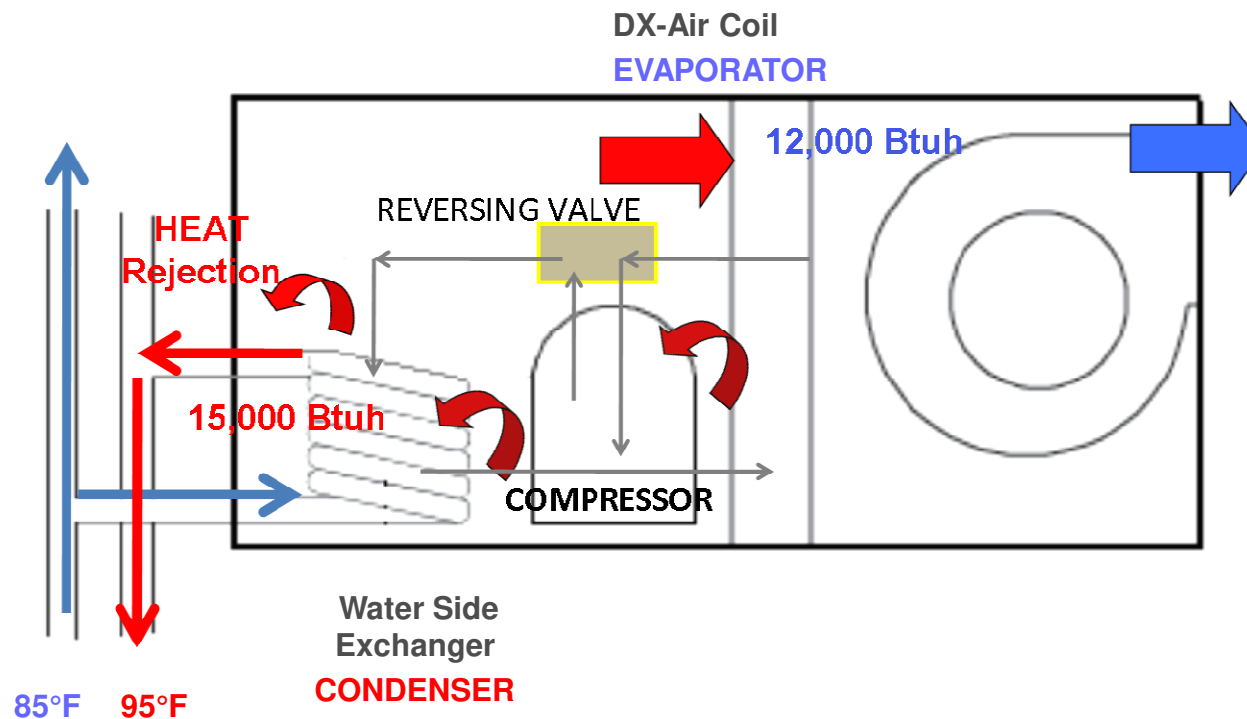

# WSHP Heating Mode

In the heating mode, a reversing valve is energized and reverses the flow of the refrigerant. The air coil now becomes a condenser, and the water side heat exchanger becomes an evaporator.

As the evaporator absorbs heat, the fluid loop decreases in temperature (from 70°F to 60°F). The absorbed heat is then transferred to the compressor where more heat is added (heat of compression), and the total heat is then delivered to the condenser (air coil), where the air absorbs the heat in order to warm up the air flow.

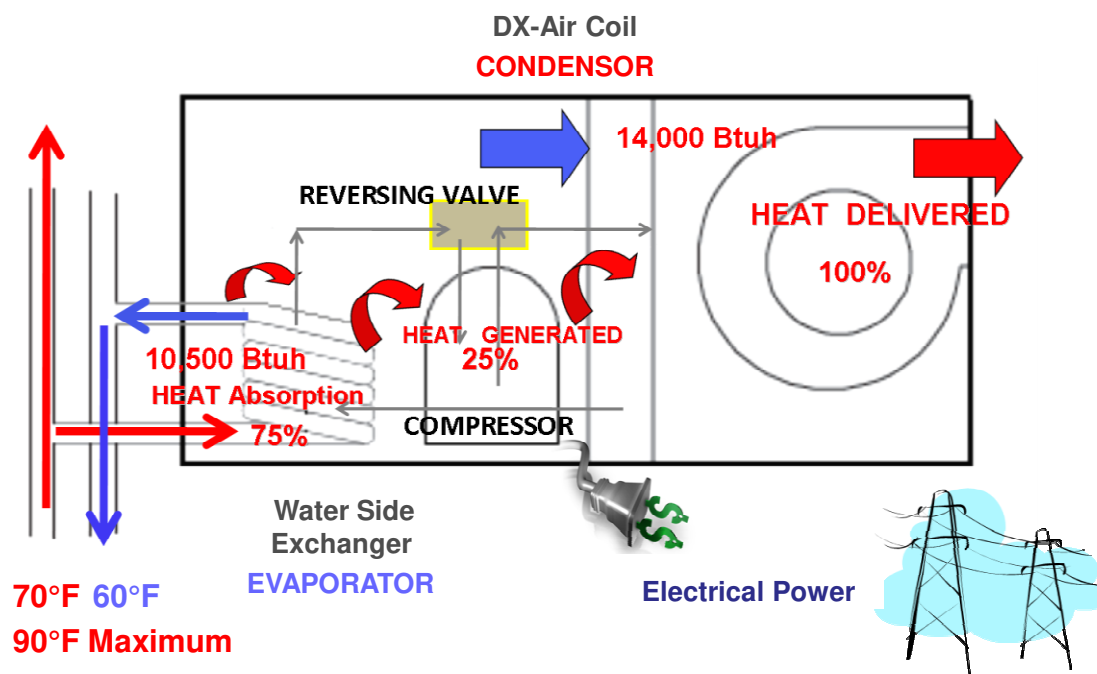

Approximately 75% of the heat is absorbed from the fluid loop, and the heat of compression consists of approximately 25% of the heat delivered to the air stream.

# WSHP Heating Mode

There are two limitations with this operation. The first is that manufacturers will not allow operation of a WSHP system if the fluid loop is greater than 90°F. The second limitation, for the purposes of this discussion/presentation, is that the compressor must operate (and therefore consume electrical power) in order to move heat from the fluid loop to the airstream.

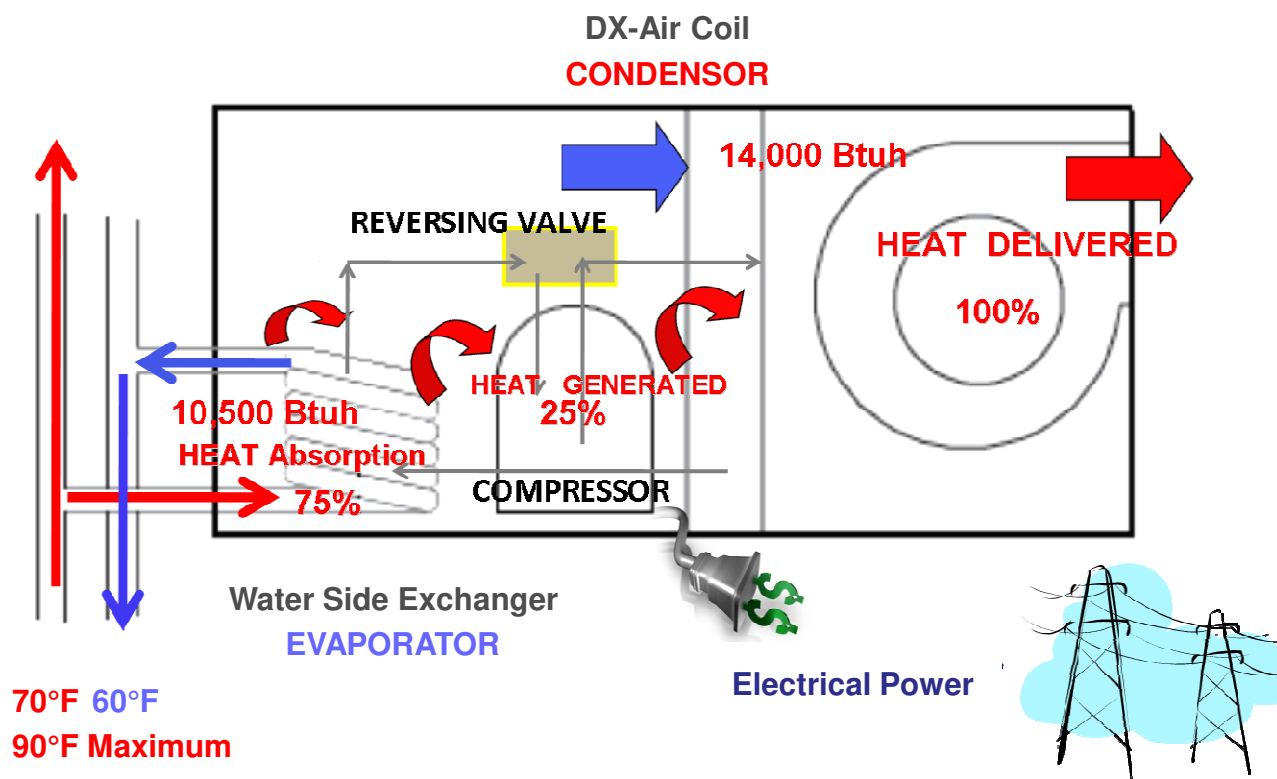

# Heat Sources

The heat a traditional WSHP unit delivers comes from two sources. Approximately three-quarters ( $\frac{3}{4}$ ) of the heat is moved from the fluid loop while the remaining quarter ( $\frac{1}{4}$ ) is derived from electricity. The heat from the fluid loop can be either the heat of rejection from the cooling units, boiler supplied heat, or a combination of both. Since the compressors are always required to move this heat, there will always be a portion of heat that is derived from electricity.

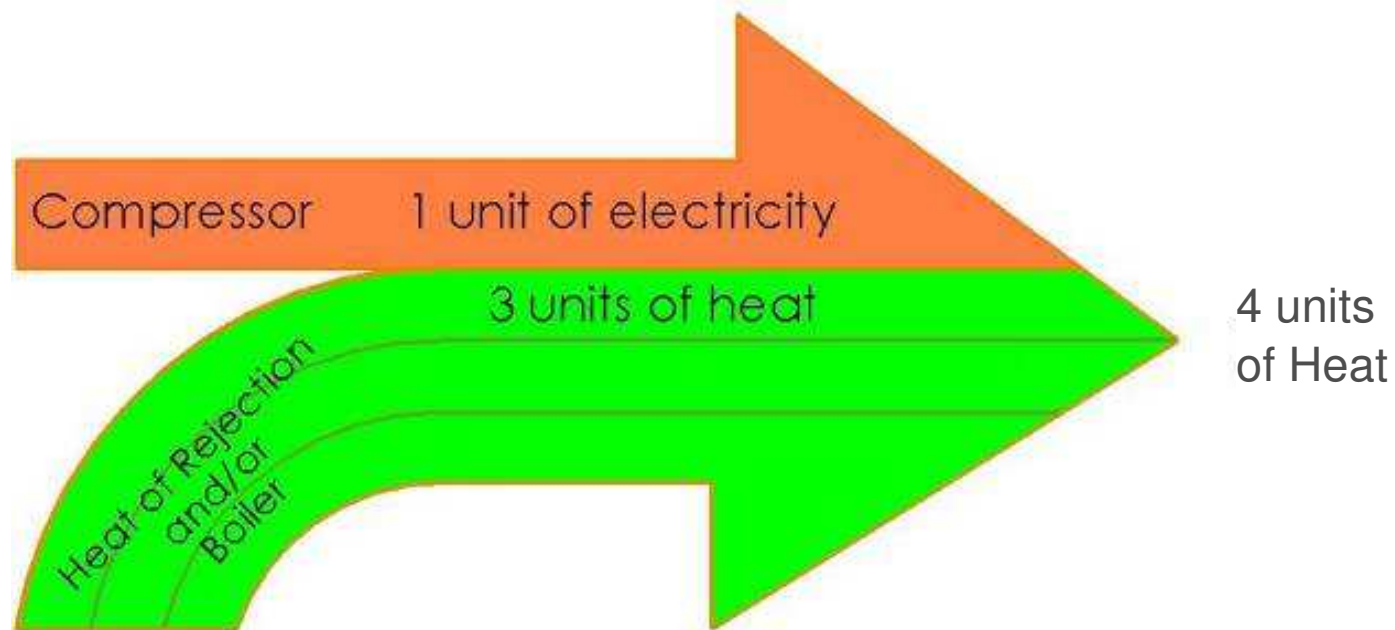

# Coefficient of Performance

Coefficient of performance (COP) is a term often used to show how much heat is delivered by a WSHP (heating capacity output) compared with how much energy the WSHP consumes (amount of energy input). Basically, it is a ratio of the useful energy delivered as heat, divided by the amount of energy used to deliver the heat.

$$\text{COP} = \frac{\text{heating capacity Btuh/hr}}{\text{watts} \times 3.413 \text{ Btuh/w-hr}}$$

$$\text{COP} = \frac{75\% \text{ fluid heat} + 25\% \text{ compressor heat}}{\text{compressor energy} + \text{fan motor}}$$

$$3.5 = \frac{3 + 1}{1 + .15}$$

$$\begin{aligned} 3413 \text{ Btuh} &= 1 \text{ kW} \\ 3.413 \text{ MBH} &= 1 \text{ kW} \end{aligned}$$

The message here is that a WSHP produces 3.5 units of heat with only 1.15 unit of energy input. The reason this is possible is due to the fact that 3 units of heat was moved from the fluid loop.

---

---

# Hybrid Heat Pump Systems

---

---



# Introduction

A hybrid heat pump system is a novel combination of two traditional commercial HVAC building technologies. The system combines conventional water cooled air conditioning and hydronic space heating, all in one package. The results include quiet operation of the unit, increased energy savings, longer life and lower maintenance, all with less technical risk.





# Hybrid Heat Pump Cooling Mode

In cooling mode, the hybrid unit is a water cooled air conditioner like any other. The air-to-refrigerant coil acts as the evaporator and absorbs heat from the air passing over this DX coil. The evaporated gas is compressed by the compressor and delivered to the condenser, which is a water-to-refrigerant exchanger.

When the gas condenses, it releases the heat to the fluid. The fluid heat is available for use as building heat, and if there is no heating requirement, the heat is rejected to the fluid cooler.

This cycle is identical to that of a traditional WSHP.

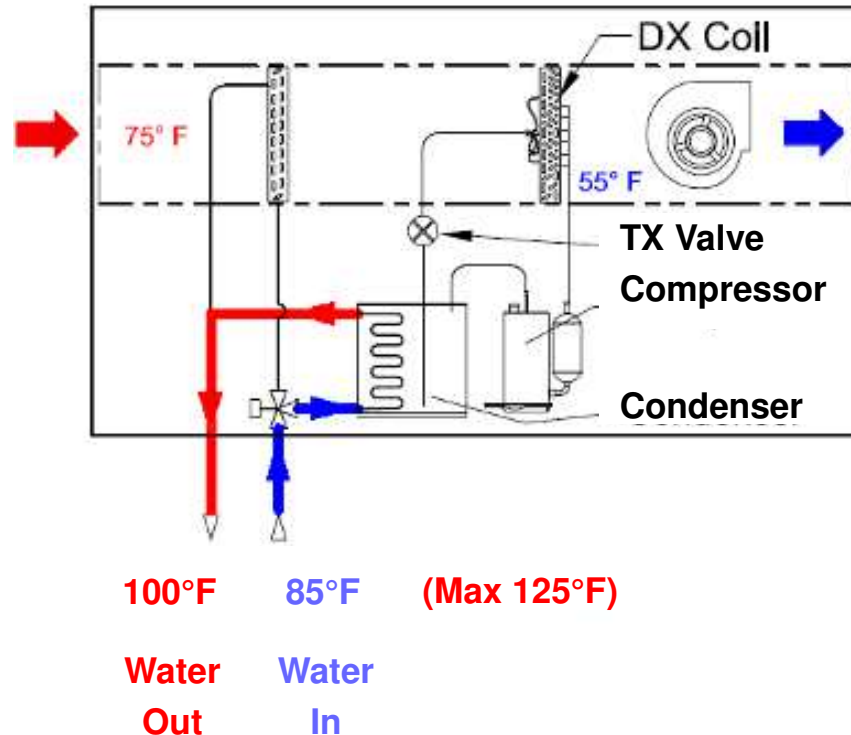

# Hybrid Heat Pump Heating Mode

It is in the heating mode where we see the main difference between a hybrid system and a traditional reversing WSHP system.

The hybrid unit does not have a reversing valve, and therefore does not reverse the flow of refrigerant. In fact, the unit does not use mechanical operation in the form of a compressor to deliver heat. Instead, a hydronic heating coil extracts heat from the fluid loop, as opposed to an evaporator, as is the case in a reversing system.

Remember, the heat always comes from the fluid loop. The hybrid unit simply extracts the heat without compressor operation. Basically, the hybrid unit operates as a simple fan coil in the heating mode.

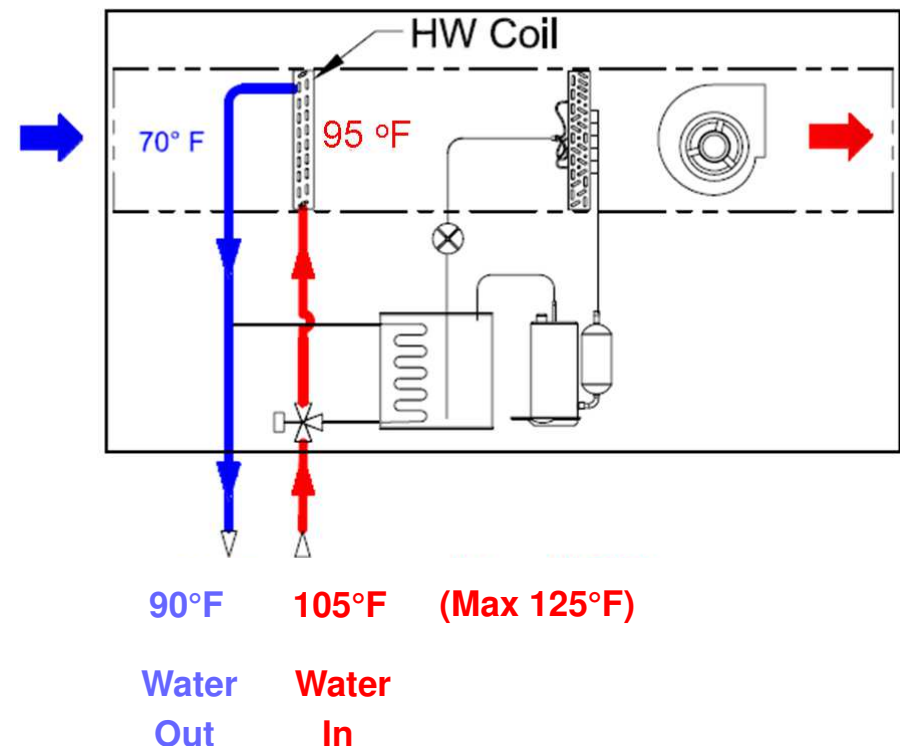

# Hybrid Heat Pump Heating Mode

Earlier discussions referred to two limitations of a traditional WSHP system (90°F limit, and compressor power – see slide 13). With a hybrid heat pump system, these two limitations do not exist—the fluid loop maximum temperature is 125°F, and the compressor power requirement has been completely removed.

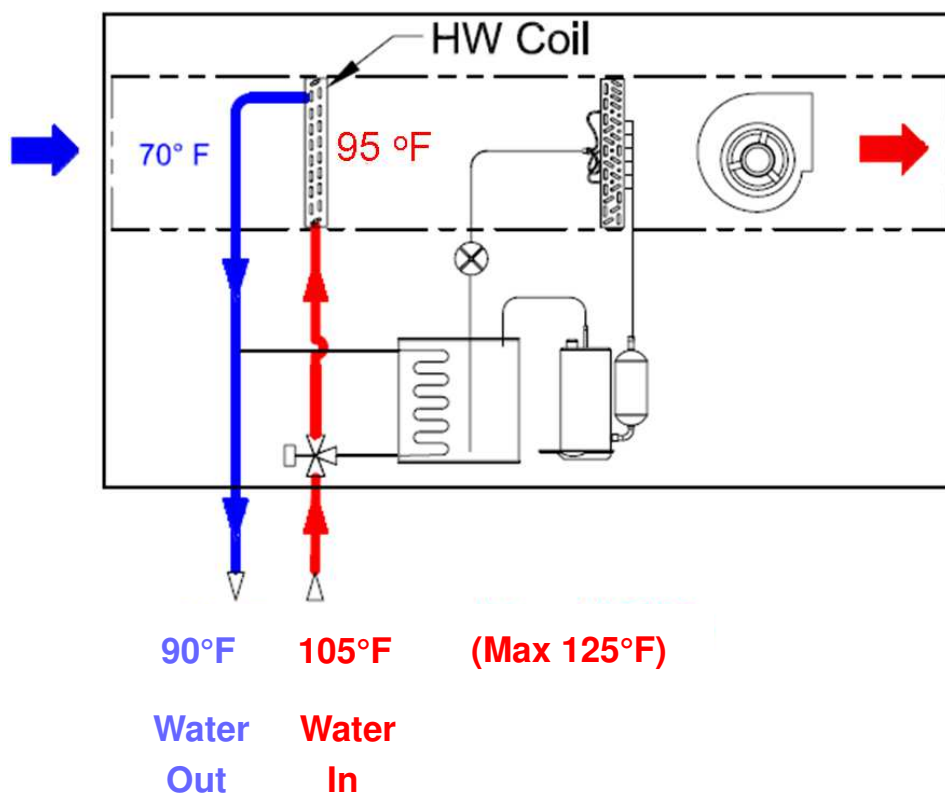

# Heat Sources

Unlike a standard WSHP system that requires compressors to move heat (and subsequently generate electrical heat), the hybrid unit acquires **all** of the heat from the fluid loop.

This heat is either heat of rejection from the cooling units, boiler supplied heat, or a combination of both.

The major difference between the two systems is that with a hybrid unit, **none** of the heat comes from electrically driven compressors.

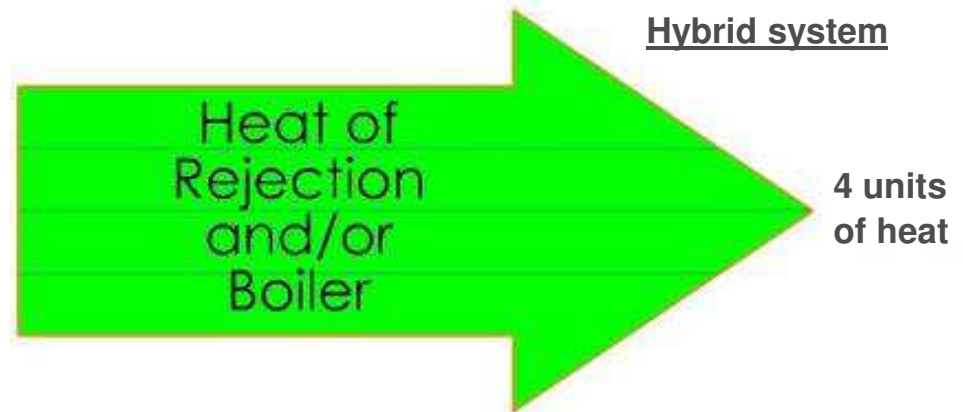
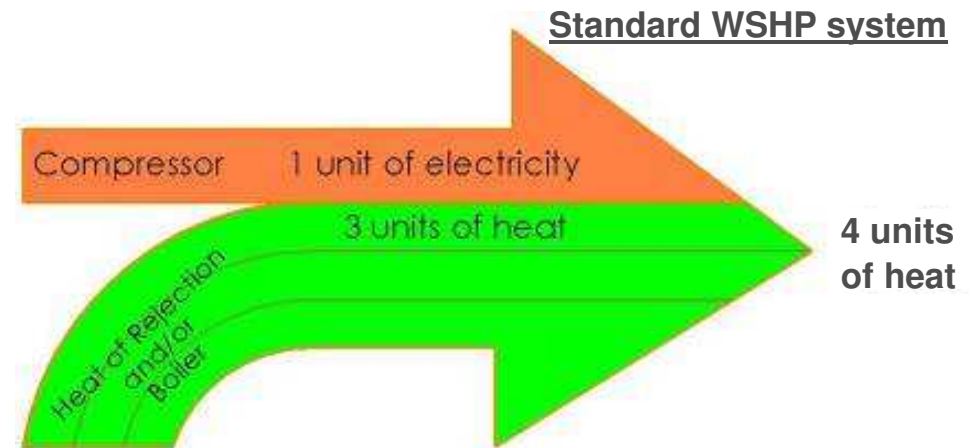

# Loop Temperature

The hybrid heat pump system has one additional component compared to that of a traditional reversing WSHP system. The hybrid system has an outdoor air sensor, the purpose of which is to schedule the fluid loop temperature to the ambient conditions, and therefore provide sufficient heat based on the actual heating demand load.

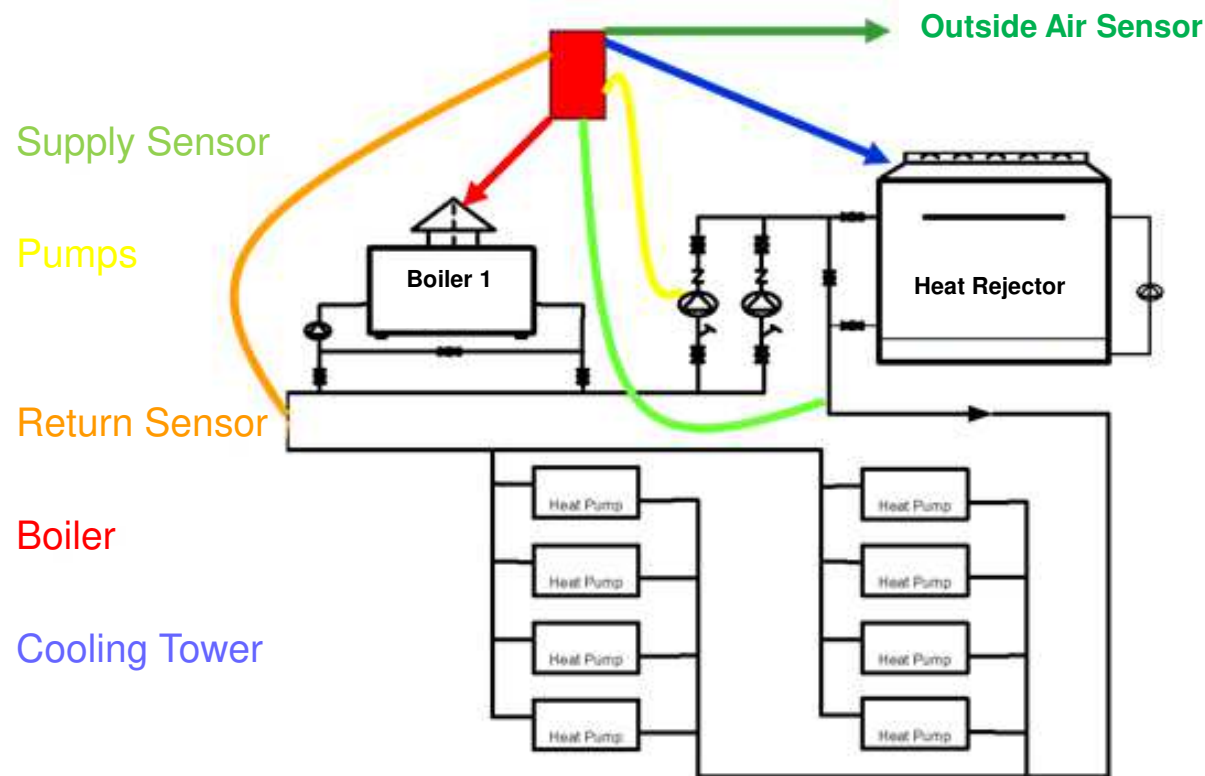

# Loop Water Reset Schedule

We know that if the ambient temperature is above 55°F, a standard loop temperature of 85°F is usually sufficient to satisfy the heating load. As the ambient conditions get colder, the loop temperature is scheduled upwards in order to deliver sufficient heat. From industry experience, we know that in colder climates there is rarely a need for loop temperatures in excess of 112°F. However, if required, the loop temperature will be increased to meet the load. In order to allow the cooling units to deliver mechanical cooling, the maximum allowable fluid temperature is 125°F.

**Hybrid Heat Pump Loop Temperature (°F) vs. Outside Air Temperature (°F)**

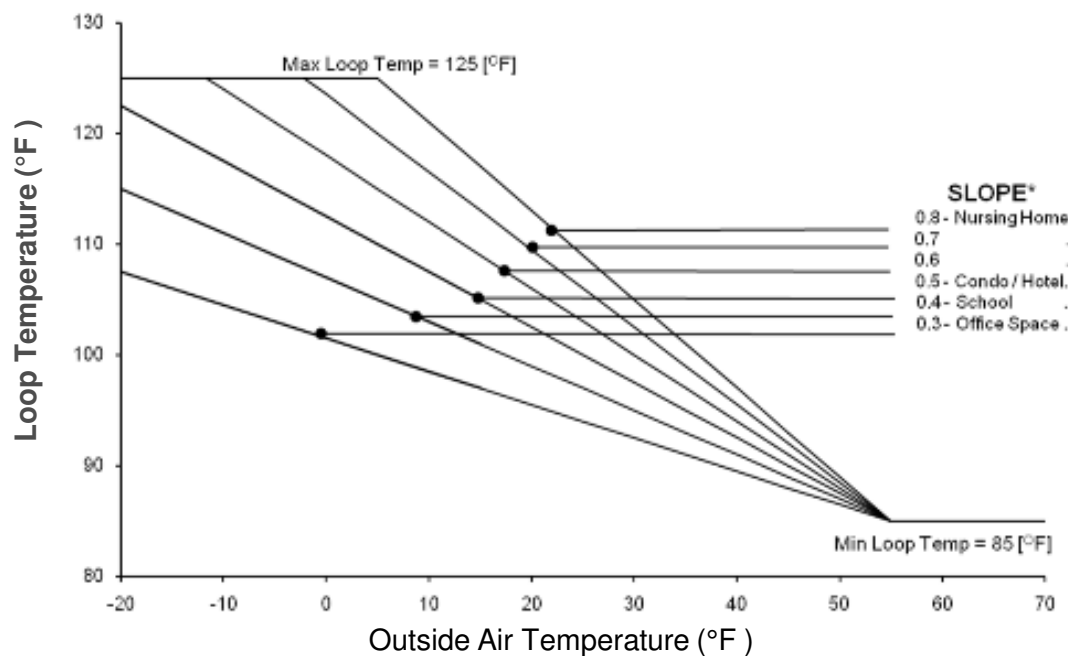

# Heat Requirements

A common question asked regarding the hybrid system is whether there is enough heat in the loop to satisfy the heating load, given that the system is missing the compressor heat. The simple answer is “yes”—but this leads to another question: “How much heat is actually required?” and, “Is it necessary to have a leaving air temperature of 90°F, 100°F, or maybe 105°F?”

The answer depends on the season and how much heat is required. Since the hybrid unit operates as a fan coil in heating mode, it will deliver exactly the amount of heat required, at any time of year. This is contrary to a reversing WSHP system, which delivers full heating regardless of the season/time of year.

# Heat Requirements

The hydronic heating coil is selected to extract approximately 70% of the difference in temperature between the entering air and the entering water. Therefore, if there is an entering air temperature (EAT) of 72°F and an entering water temperature (EWT) of 110°F, the temperature rise of the air will be approximately 28°F, for a final leaving air temperature (LAT) of 100°F. Of course, if this is not sufficient, the boilers will inject more heat into the loop.

If EAT = 72°F

If EWT = 110°F

Then, air temperature increase is = 28°F

$LAT = 72^{\circ}F + 28^{\circ}F = 100^{\circ}F$

However, ASHRAE (The American Society of Heating, Refrigerating and Air-Conditioning Engineers) says a delta-T of 15°F voids compliance with *ANSI/ASHRAE Standard 55-2004, Thermal Environmental Conditions for Human Occupancy*. This standard states that a LAT which is much higher than the room set point may cause stratification, so that a portion of the heat never reaches the occupied space. Therefore, having a LAT which is too high may not be a good idea.



# Pipe Insulation

ASHRAE 90.1-1989, section 9.4.8.2, stipulates that all HVAC system piping shall be thermally insulated in certain conditions, with some exceptions:

*(b) Piping that conveys fluids having a design operating temperature range between 55°F and 105°F.*

This exception is clearly directed towards WSHP systems. In the case of a hybrid system, since the water loop temperature will be above 105°F in the heating season, one of the exceptions that is more relevant is:

*(d) ... where it can be shown that the heat gain or heat loss to or from the piping without insulation will not increase building energy costs.*

Or, according to ASHRAE 90.1,2007...6.4.4.1.3

*(c) ...or where heat gain or heat loss will not increase energy usage.*

# Pipe Insulation

Since the water temperature in a hybrid system rarely goes above 112°F, due to the insulating values of new buildings, there should be very little heat loss. Regardless, the hybrid system actually reduces energy consumption by turning off compressors in the heating mode.

Furthermore, the hybrid heat pump operates on a system process which reclaims the heat generated within a building to directly satisfy the heating needs of the building. By not generating extra heat with the compressors, the hybrid system can reclaim more heat from the fluid loop than a traditional WSHP system. It is quite easy to understand that even if temperatures go above 105°F for a period of time during the winter months, the hybrid system actually results in lower total building energy consumption.

---

---

# Heat Extraction & Recovery

---

---

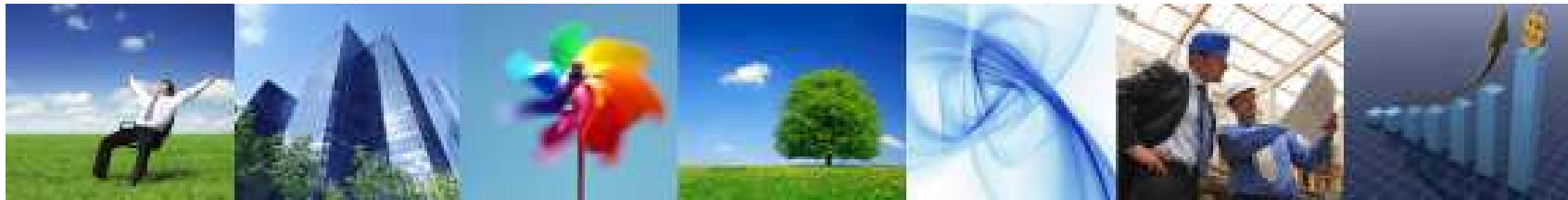

# Reclaiming Heat

The process of reclaiming the heat generated within a building to directly satisfy the heating needs of the building, without additional energy input, is a very critical component of the hybrid heat pump system.

In simple terms, this process refers to the ability of the system to reuse all of the “waste” heat of compression from the cooling units to satisfy the required heating load— without additional energy input.

This can be accomplished during the intermediate seasons when there is enough heat of compression from the cooling units to satisfy the heating requirement. It also implies that the heat is “free” if you do not have to run compressors to acquire it.



# Traditional Reversing WSHP Systems

Traditional WSHP units may reject heat while simultaneously generating heat from compressors and make-up-air units. This may happen during the intermediate seasons, spring and fall.

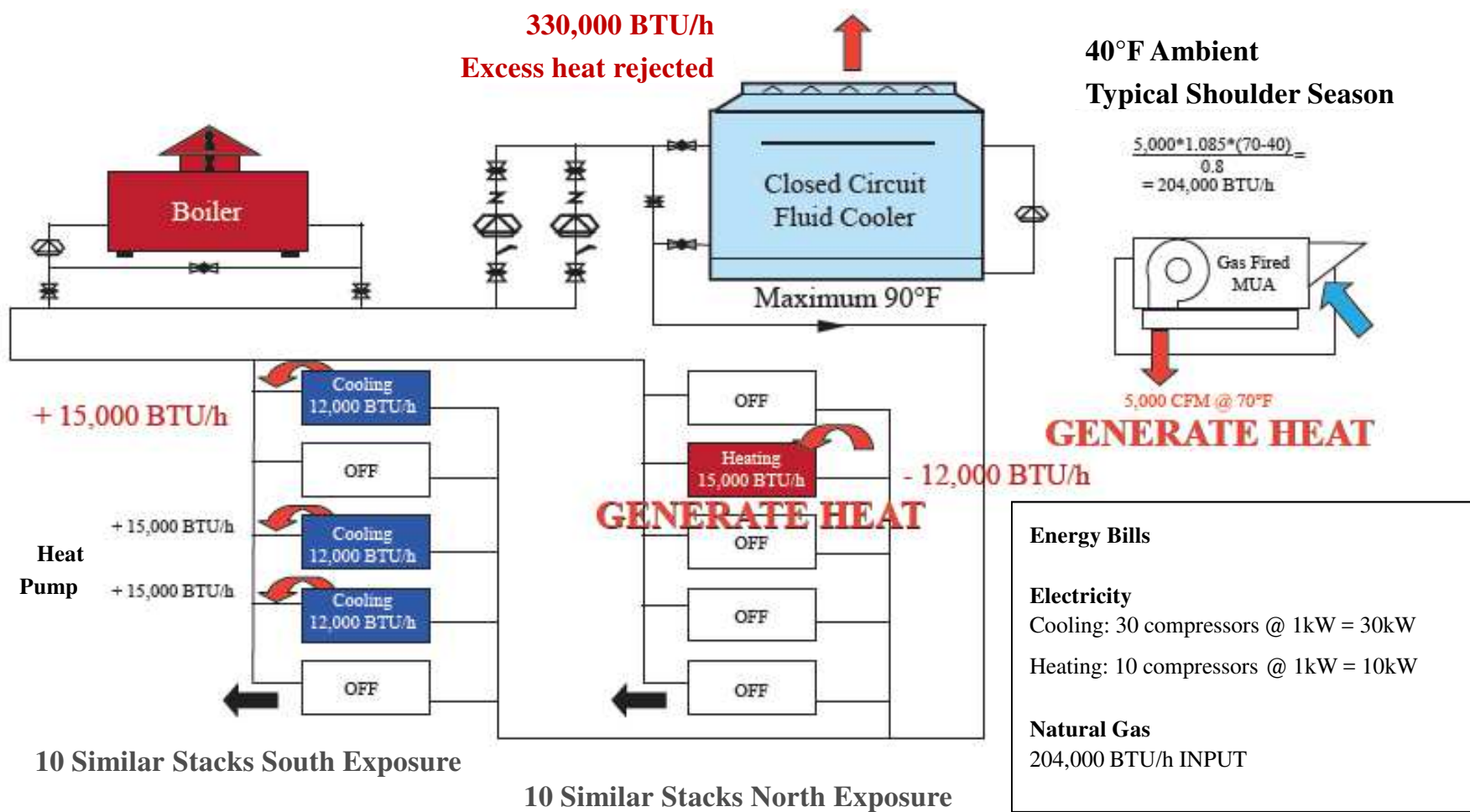

# Traditional Reversing WSHP Systems

Listed here are some of the limitations of a traditional reversing WSHP system.

Heating units cannot absorb as much heat as is rejected by the cooling units. Therefore, if there are more units in cooling than heating, there will be a surplus of heat which must be wasted to the fluid coolers.

When some units are in cooling and some are in heating, some exchangers will be condensers and some will be evaporators. The fluid loop must therefore have a temperature range that can satisfy both modes of operation. But, the fluid loop cannot be allowed to go above 90°F or else the heating units will not operate. Typically, a temperature range of 70°F to 90°F has to be maintained. If there is an abundance of cooling units rejecting a lot of heat into the loop, the fluid cooler will be used to lower the loop temperature.

A major point is that while the fluid coolers are removing excess heat, make-up-air units may be using a fuel source to heat the ventilation air. So, a reversing system may be rejecting heat, while simultaneously generating heat.

# Hybrid Heat Pump System

As mentioned, a hybrid heat pump system will save electricity by not operating the heating compressors. In addition, it will lower a building's total energy consumption by conserving and reclaiming energy.

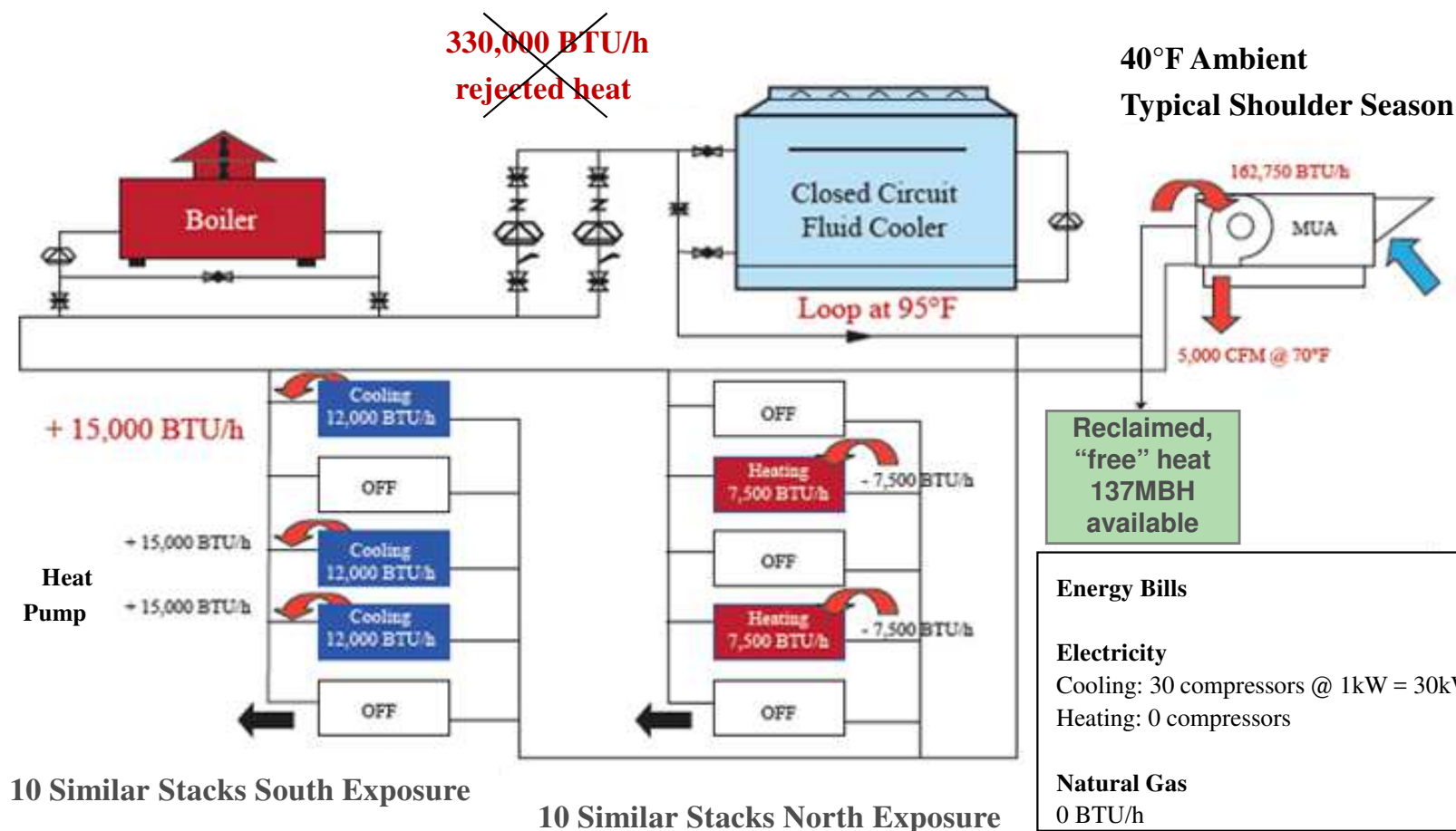

# Hybrid Heat Pump System

Instead of preventing the fluid loop temperature from going too high, the hybrid system actually promotes warmer fluid loop temperatures, and therefore minimizes how much heat is wasted to the fluid coolers.

The total heat rejected by the cooling units, or “waste” heat, is maintained within the loop and is available throughout the building to satisfy the heating requirements. One example of where “waste” heat can be used is for make-up-air heating instead of gas fired units. This is possible since in the heating mode, the hybrid system operates as a fan coil and actually requires warm fluid. This is contrary to a reversing WSHP system, which has evaporators to extract heat from the fluid loop and requires cooler fluid.

Of course, boilers are always available to inject supplemental heat if required, which is consistent with either system. Even with elevated loop temperatures, hybrid units can still deliver mechanical cooling.



# Utilizing “Waste” Heat

In many buildings, there is a year-round cooling requirement which can provide a significant amount of “waste” heat. With fan coil type heating, this “waste” heat can be used for a wide variety of heating purposes.

In some cases, the hybrid system removes the need for a separate high temperature water loop. The recovered “waste” heat can be used for many purposes including: pool heating, snow melting, radiant underfloor heating, perimeter heating, and garage heating.

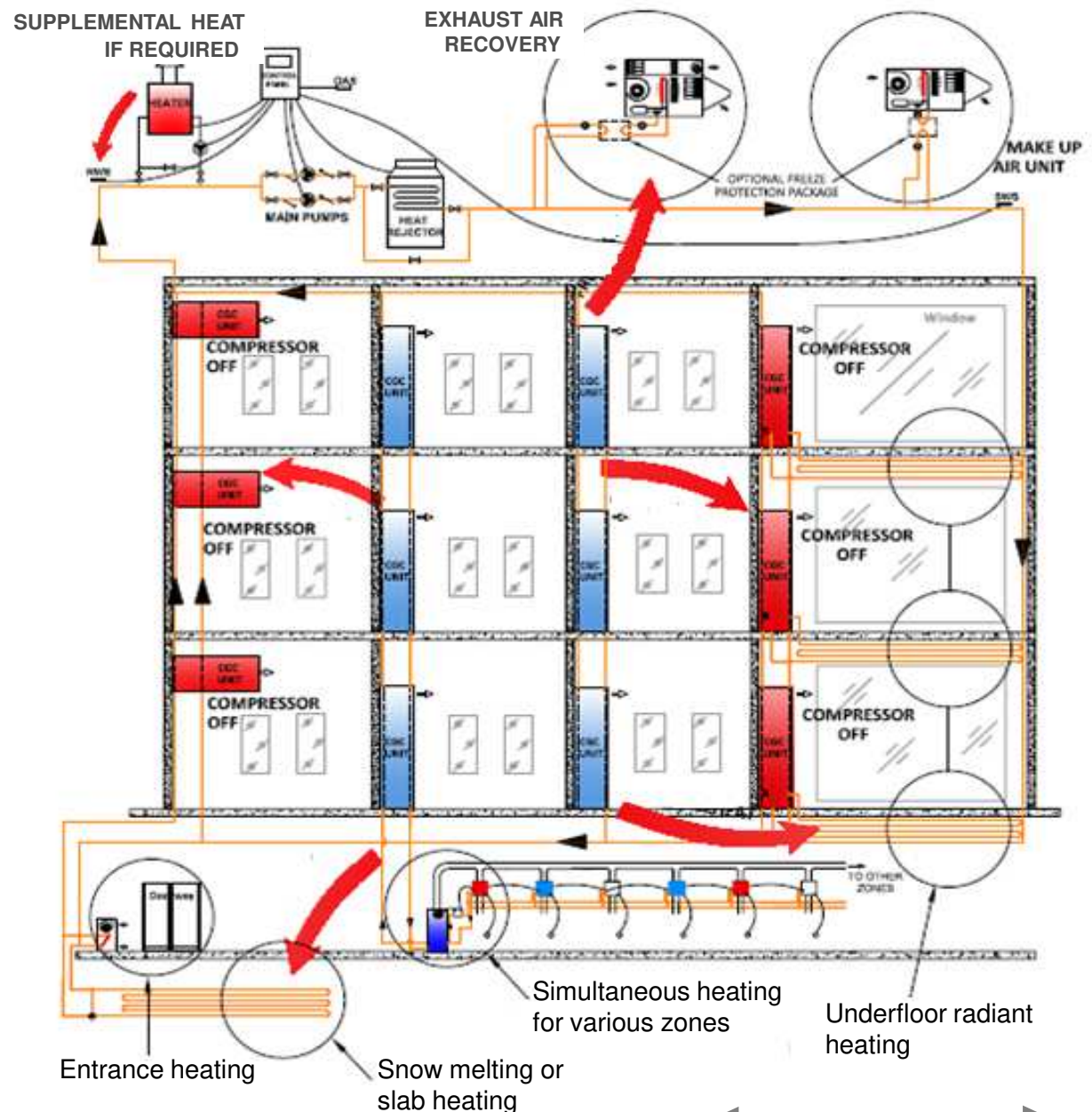

# Utilizing “Waste” Heat - Cold Wall Barrier

## The Challenge

Modern buildings, often constructed with large glass areas to provide spectacular daylighting and views, present occupant comfort challenges. Heating a space near full-height windows may become expensive and difficult.

Often, the result is an almost uninhabitable cold space at the perimeter of the living space, with cold drafts commonly referred to as “the cold wall effect.”



360 On Pearl  
360 Pearl Street, Burlington, ON

# Utilizing “Waste” Heat - Cold Wall Barrier

## The Solution

A special hybrid unit application utilizes the “waste,” warm, heat pump fluid loop for radiant in-floor heating as the first stage of heat.

Treating the problem at the source with radiant heat eliminates cold spots and downdrafts and provides greater comfort.

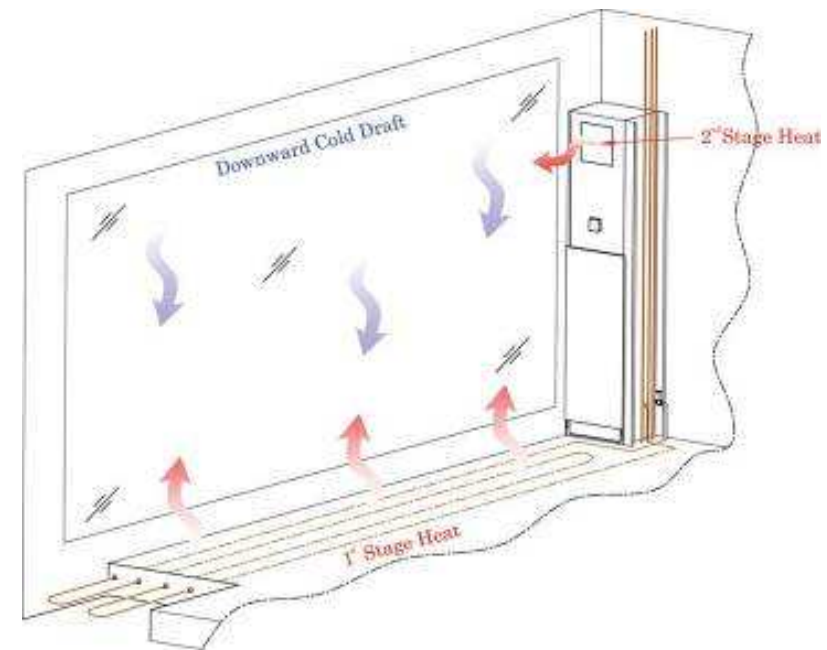

- 1st stage heating – in-floor perimeter radiant heating.
- 2nd stage heating - hybrid heat pump hydronic coil.
- Eliminates cold wall effect due to large glass areas.
- Valves and controls built into a vertical stack hybrid heat pump.

# Utilizing “Waste” Heat - Snow Melting

An example of utilizing “waste” heat is at the Nelligan Hotel in Montreal, QC, where heat is reclaimed from the compressors, removed from the restaurant and suites, and then used for snow melting in the skylights and heating the garage.



---

---

# Energy & Economics

---

---

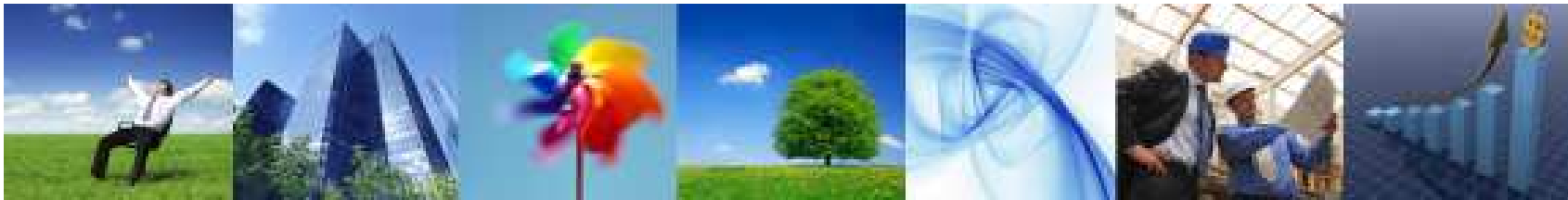

# Electrical Consumption

This graph illustrates the consumption of electricity of 100 heat pumps (one (1) ton each) in one (1) hour. The red columns represent the electricity consumed by reversing WSHP units, and the green columns represent the electricity consumed by the hybrid heat pump units.

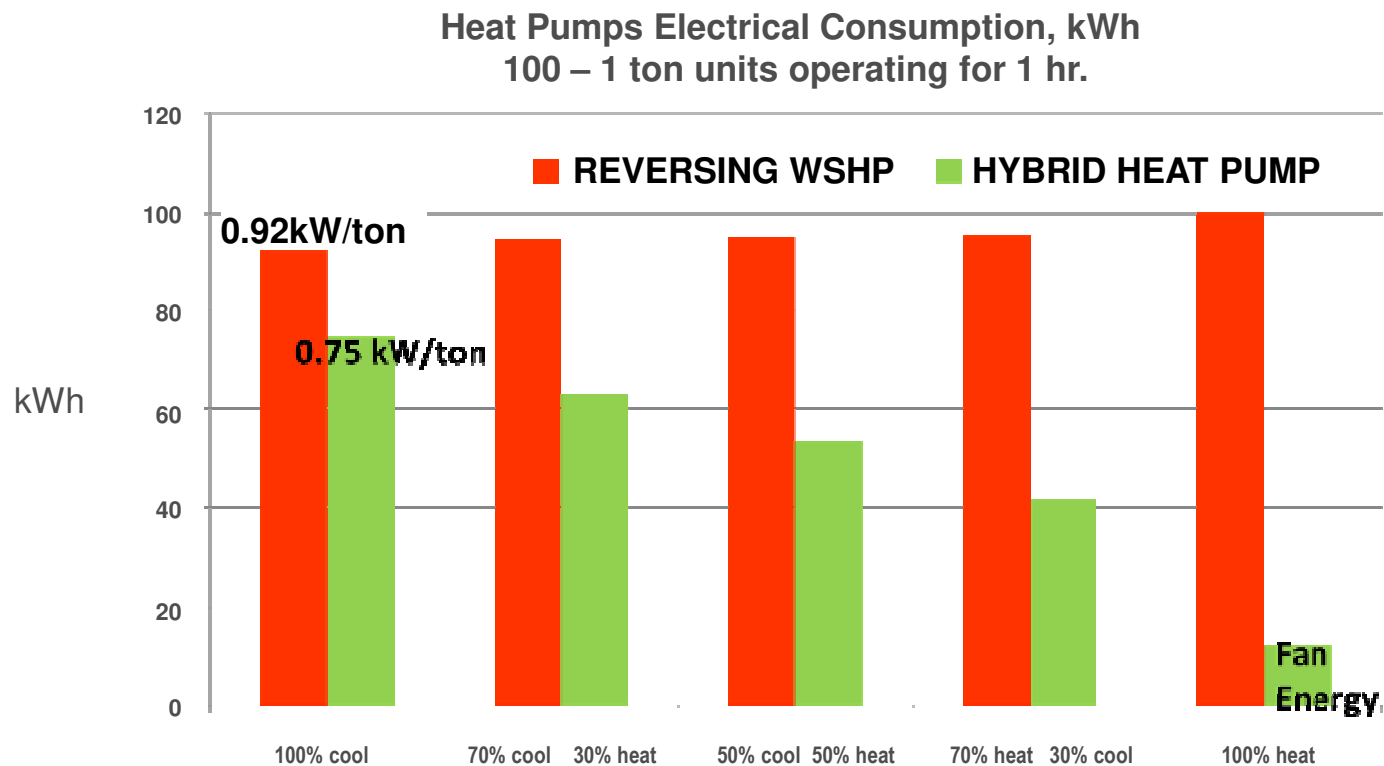

# Electrical Consumption

In 100% cooling mode, all of the compressors are operating—in both the WSHPs and hybrid units. (Note, the consumption of electricity of the hybrid units may be lower due to the higher efficiencies.) However, as we move away from the 100% cooling season into the intermediate seasons, the hybrid systems will turn off the heating compressors, while the reversing systems will still have all of their compressors operating (either heating or cooling mode).

The hybrid systems will still provide heat when required, but they simply will not use compressors to extract heat from the fluid loop. During the heating months, if all of the units were ever to be in the heating mode simultaneously, we would see that the reversing WSHP system would still have all of the compressors operating, whereas the hybrid system would only have the fans operating.

# Energy Consumption

The best operating point for a standard WSHP is with cold condenser water in the winter/heating mode. This graph illustrates the energy consumption of a WSHP unit with a 70°F entering fluid temperature. The cooling unit is very energy efficient with 70°F fluid entering the condenser (0.72 kW/ton cooling mode), but not so much with 70°F entering the evaporator( 0.97 kW/ton heating mode). The worst possible time for a hybrid system is with warm fluid in the winter mode. The graph shows the energy consumption of the hybrid units with 110°F entering fluid temperature.

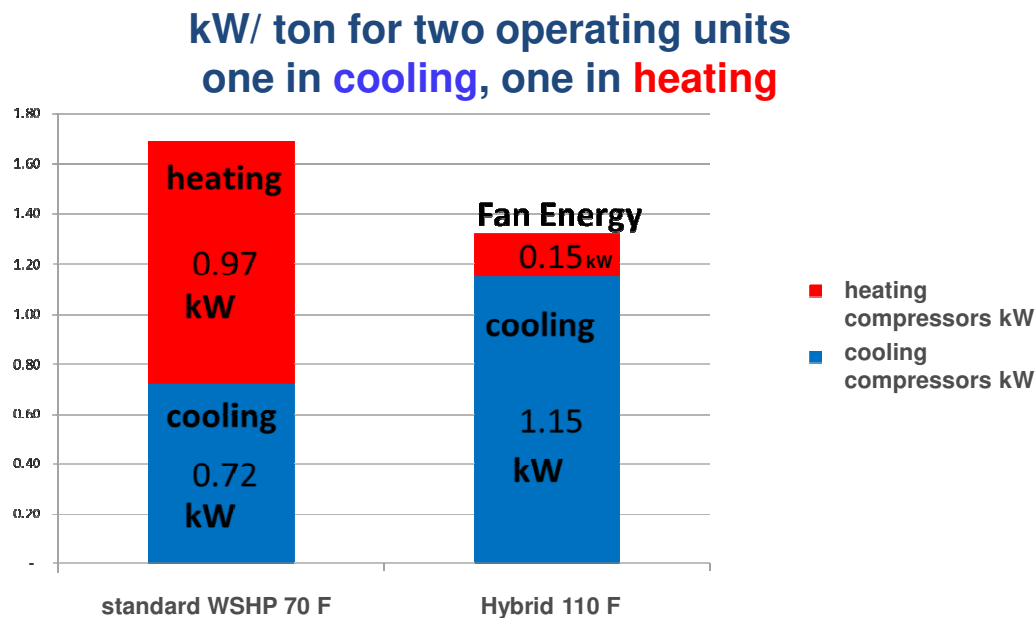



# Energy Consumption

Comparing the two, we see that even at its worst possible operating point (1.15 kW/ton cooling mode), the hybrid system still consumes less energy, simply by turning off the heating compressors (0.15 kW is fan energy only).

With the hybrid system, as the operating mode moves into the spring/fall, more units may be calling for cooling, and the fluid temperature will be cooler than the maximum winter design loop temperature.

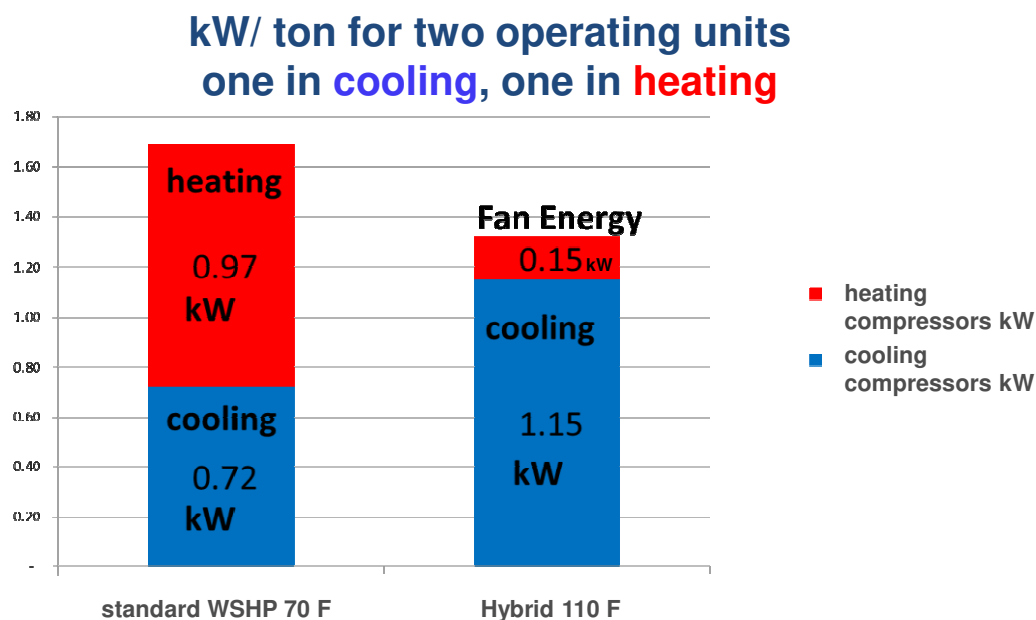

# Electrical Consumption

In a hybrid system, mechanical cooling will always be available up to a maximum fluid temperature of 125°F. However, in most cases, fluid temperatures greater than 115°F are rarely required, even in very cold climates. Operating cooling units with elevated fluid temperatures in the winter heating season will reduce their energy efficiency. However, the penalty for operating with elevated fluid temperatures for a limited period in peak heating mode will be minimized if high efficient models are used.

This graph compares the electrical consumption of WSHP units operating with 70°F fluid, and hybrid units operating with 110°F fluid. The only time the hybrid system may require 110°F is during peak winter design conditions when most of the units would be in the heating mode, except for possibly interior zones.

**kW/ton Electrical comparison, winter operation**  
**three units in heating , one unit in cooling**

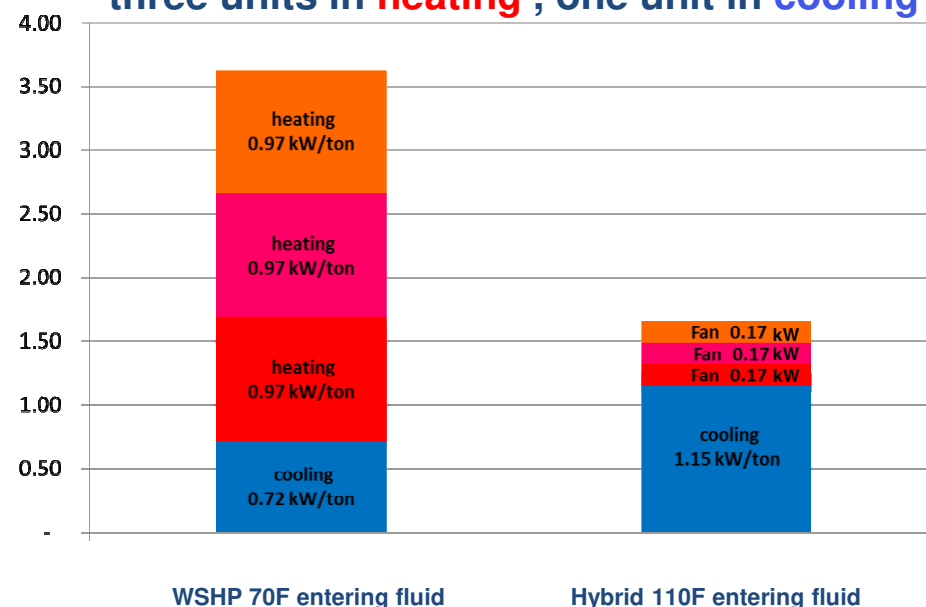

# Energy Consumption

Therefore, for this example, it is assumed that 75% of the units are in heating and only 25% in cooling. This is a very simplified snapshot, but it clearly demonstrates the electrical benefits of turning off the heating compressors even if the cooling units are operating with elevated fluid temperatures. The electrical meter is on the entire building and not simply on the cooling units. It will always be more advantageous to turn off heating compressors, even it means paying a penalty on cooling units.

**kW/ton Electrical comparison, winter operation**  
**three units in heating , one unit in cooling**

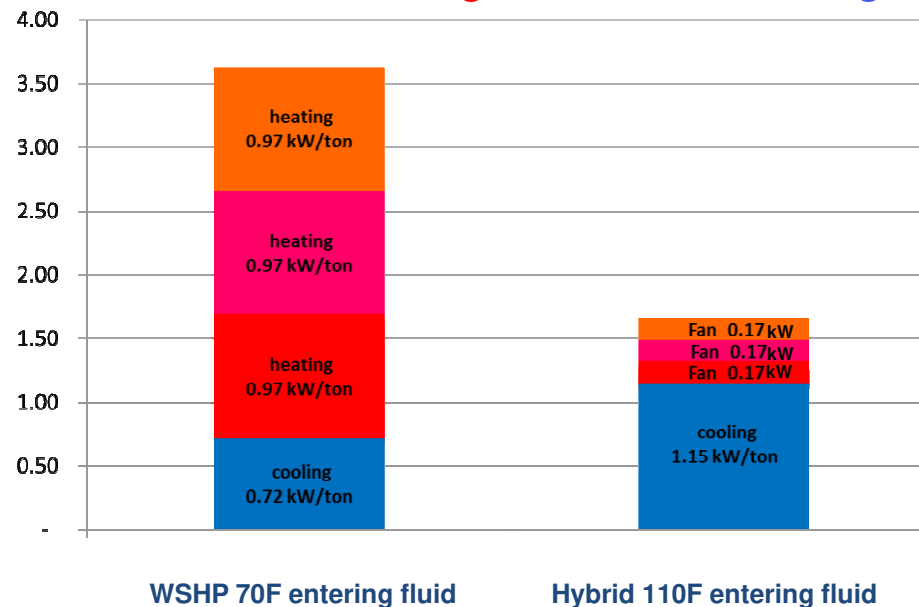

# Boiler Plant Energy Consumption

In the heating season, when there are more units in the heating mode than in cooling mode, there is a need for heat injection by a boiler plant, since there is not enough waste heat from the cooling units. The graph shows that the hybrid system will require more boiler plant heat injection since there is no heat being generated by electricity. Next, we will look into whether there is a benefit in generating heat from natural gas boilers as opposed to electrically generated heat.

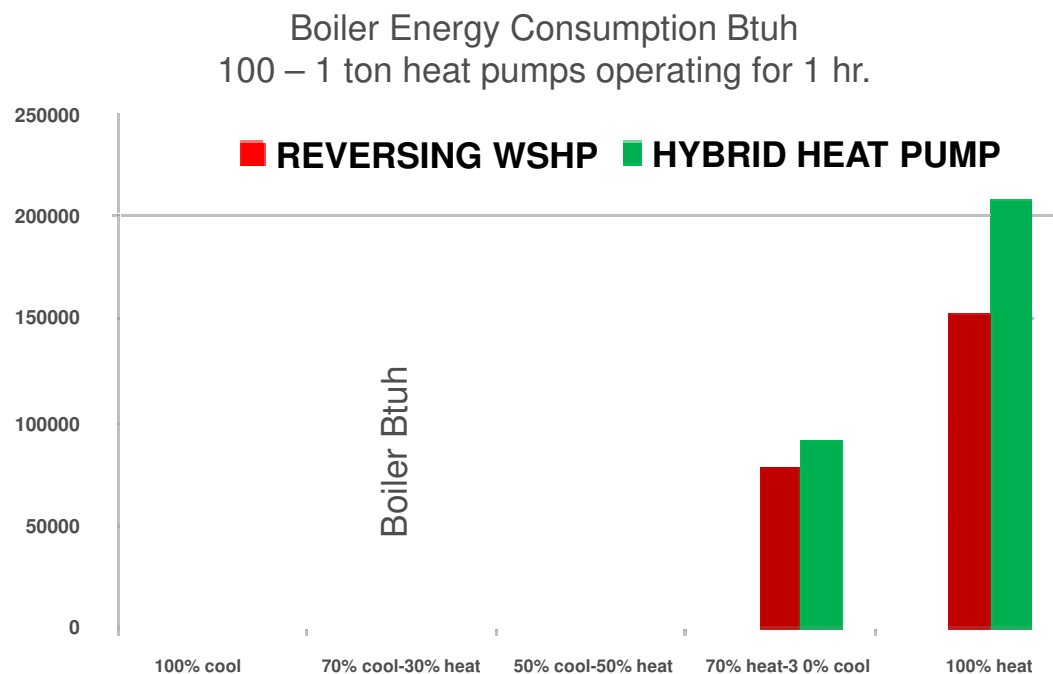

Note, the graph data does not factor in the make-up-air unit for natural consumption.

# “Fuel Switching”

“Fuel switching” may be defined as the process of moving the electrically generated heat away from the compressor, and moving this heating load to the boiler plant where a lower cost fuel source can be used. This graph compares the cost of generating one million Btuh of heat with either electricity or natural gas fired condensing boilers. Assuming an electrical rate of \$0.10/kWh, while gas is assumed to have a cost of \$1.00/therm (100,000 Btuh).

Generating one million Btuh of heat with electricity would cost \$23.45, while the same amount with a gas boiler would only cost \$10.58—this is a 45% reduction in costs for the same amount of heat. So, the 25% of the heat generated from electrical compressors actually costs 40% of the heating costs.

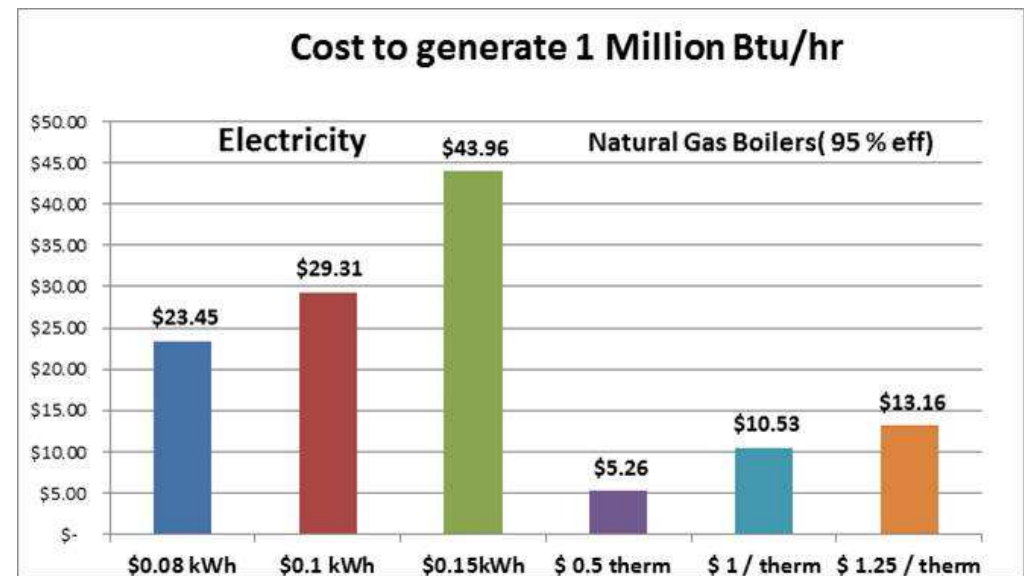

# Combined - Electrical & Boiler Energy Consumption

Converting the electrical energy consumed by the compressors into Btuh, and adding that energy to the energy consumed by the boiler plant, we see that there is a net reduction in total energy consumed by the hybrid heat pump system versus a traditional reversing WSHP system. This is clearly evident in the intermediate seasons, where the hybrid system does not operate compressors in order to extract heat from the fluid loop.

It is also possible to see a lower energy consumption in the 100% cooling mode, due to the high efficient design of the hybrid system compared with regular water source heat pumps.

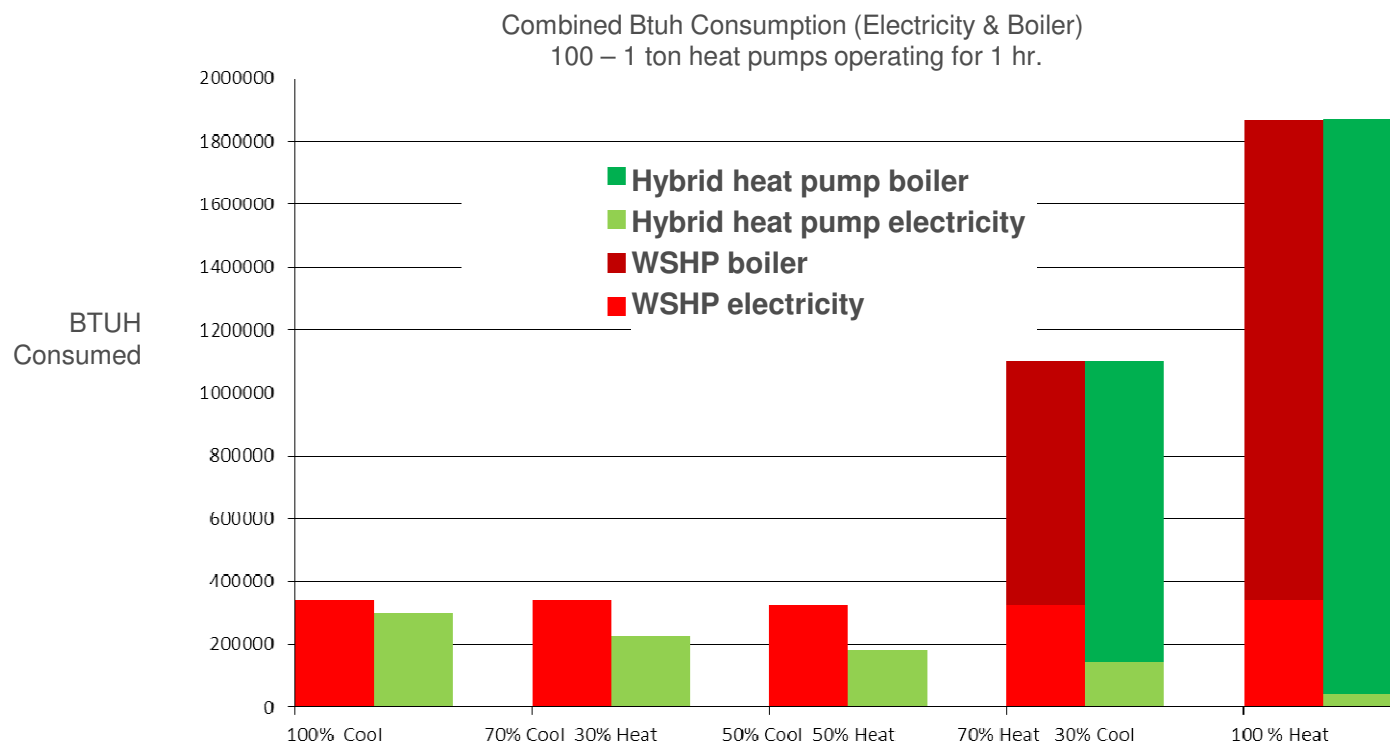

# Combined - Electrical & Boiler Energy Consumption

Of course, in the 100% heating mode, both systems must generate sufficient heat from the boiler plant to satisfy the heating requirement, since there is no “waste” heat in this condition. However, even in this condition where the amount of heat required is identical, there may be a cost advantage with a hybrid system. The reversing WSHP systems will get approximately 25% to 30% of the heat from the compressors, which are fuelled by electricity; and in most cases the cost to generate heat from electricity is more than with other types of fuel such as natural gas.

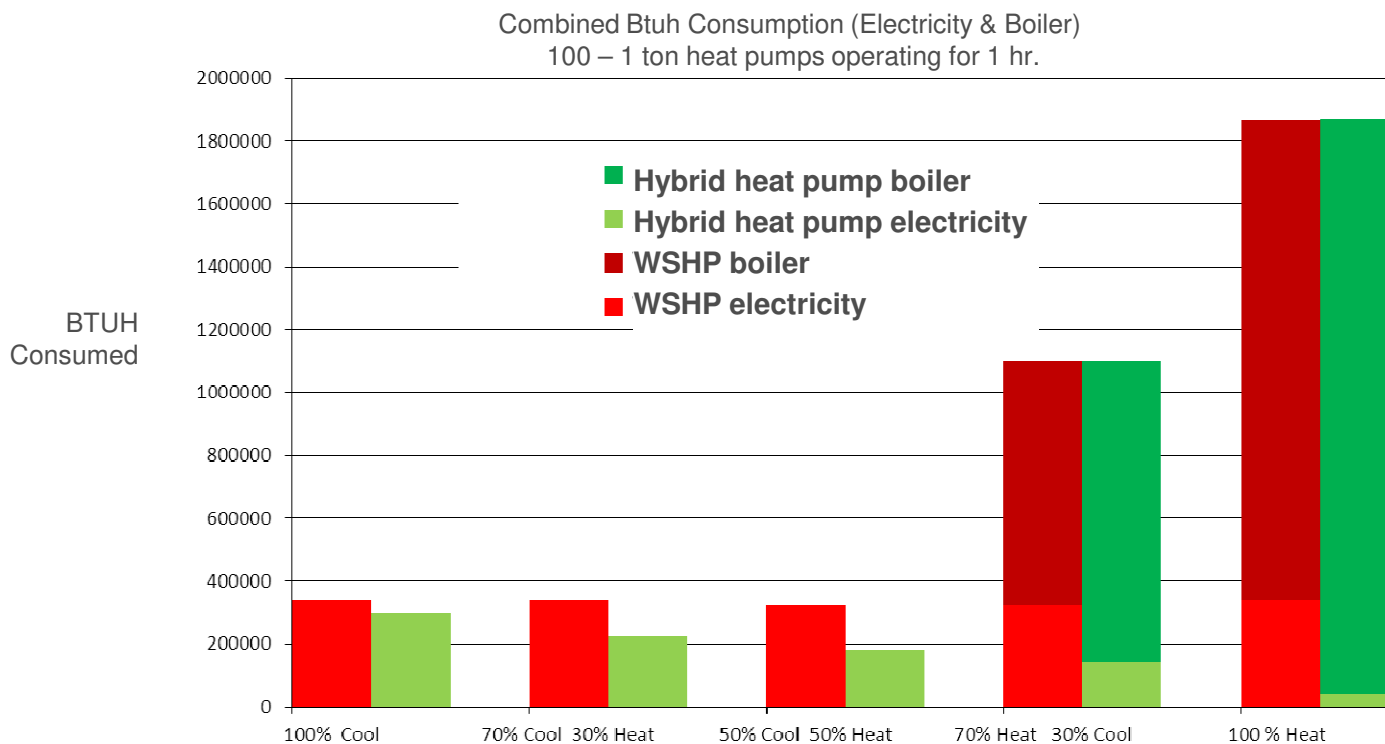

# Cost of Energy

A graphical representation for the cost of energy is provided here. The final numbers will of course vary depending on local utility rates, but as applied here, the cost of electricity is 8 cents per kWh and the cost of natural gas is \$1.28 per therm. Using these figures as applied to the previous energy consumption figures, the hybrid system offers costs savings in all seasons.

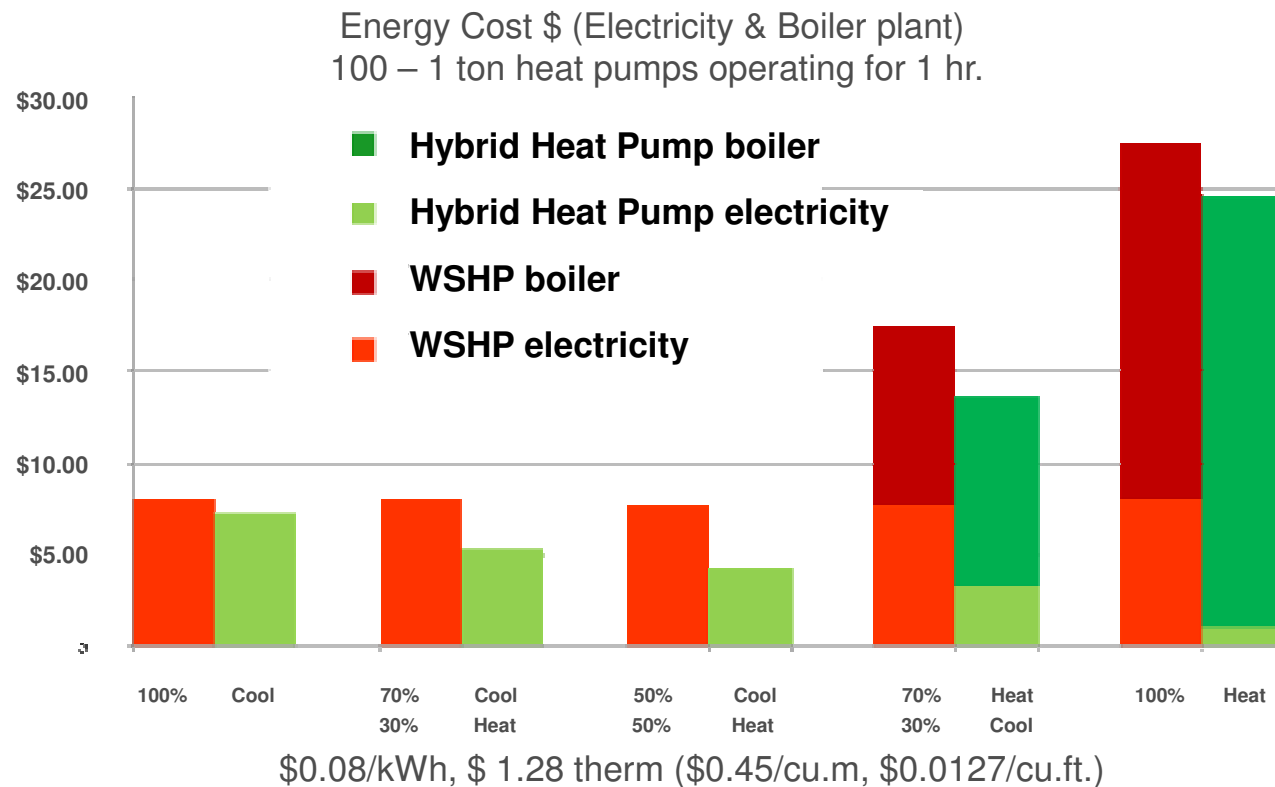



# Case Study #1 - Condominium Project

Enermodal Engineering ([www.enermodal.com](http://www.enermodal.com)) was commissioned as independent energy consultants to determine if the hybrid heat pump system offers any energy or financial benefits.



A condominium project was selected for this analysis, since it is the type of building that would yield the least favorable results for the hybrid system, due to the limited quantity of operating hours with simultaneous heating and cooling modes. Buildings such as office complexes or schools, where there may be more operating hours with simultaneous heating and cooling modes, would yield better results for the hybrid system.

# Case Study #1 - Building Energy Analysis

It is very important to note that the analysis was conducted with equal efficiencies and equal pumping rates for both systems. Regularly, the hybrid design offers better efficiencies and lower pumping rates, but for the purpose of this analysis, it was decided to provide no advantage to the hybrid system in order to focus strictly on the “waste” or “free” heat and fuel switching advantages.

## Building energy analysis

- Program used: eQuest
- Project: 50-story condominium, Toronto, ON
- Equal EERs (13 EER)
- Equal flow rates (3 gpm/ton)
- Energy costs:
  - Electricity at \$0.1115 kWh
  - Natural Gas at \$1.50/therm (100,000 Btuh)
- Weather files: Canadian weather for energy calculations (CWEC)

# Case Study #1 - HVAC Analysis

The conclusion reached by Enermodal Engineering is that the “waste” heat and subsequent reuse of heat concept would deliver a 9% reduction in energy when compare to the HVAC portion. “Waste” heat reuse is possible when the heating compressors are turned off, without the need for additional heat input from the boiler plant (or other heat source such as geothermal). This typically occurs in the intermediate seasons, spring and fall. The other main advantage of the hybrid system is fuel switching—the process of transferring the electrically generated heat away from the heat pump compressors to the boiler plant, where a lower cost fuel source can be used. In this case, natural gas fired boilers at 93% efficiency were used. Commonly, it is less expensive to heat a building with natural gas than it is with electricity. In this case, fuel switching contributed additional financial savings to bring the HVAC energy costs savings to 20%.

## HVAC Analysis

	Standard WSHP	Hybrid system	Savings
HVAC kWh	2,491,069	1,617,706	873,363 (35 %)
HVAC Therms 100,000 BTU	121,972	133,672	-11,700 (-10%)
Total HVAC energy 10e6 BTU	20,699	18,888	1,811 (9%)
<b>HVAC energy cost</b>	<b>\$416,802</b>	<b>\$332,761</b>	<b>\$84,042 (20%)</b>

# Case Study #1 - Total Building Analysis

The conclusion reached by Enermodal Engineering is that the “waste” heat and subsequent reuse of heat concept would deliver 6% total building energy reduction. Total building energy refers to the entire building, including lights and all other energy consuming components.

Again, the other main advantage of the hybrid heat pump system is fuel switching. In this case, fuel switching contributed additional financial savings to bring the total building energy cost savings to 11%.

## Total Building Analysis

	Standard WSHP	Hybrid system	Savings
Building kWh	5,245,304	4,371,941	873,363 (17%)
Building Therms 100,000 BTU	123,748	135,448	11,700 (-9%)
Total Building energy 10e6 BTU	30,277	28,466	1,811 ( 6 %)
Building energy cost	\$721,987	\$641,882	\$ 84,042 (11.6%)

## Case Study #2 - Condominium Project

Another building energy modeling on the hybrid heat pump system was performed by Viridian Energy & Environmental Consultants ([www.viridianee.com](http://www.viridianee.com)) on a 60-story condominium building in New York City, NY, called 430 W 42nd street. The structure utilized 1700 hybrid heat pumps.



## Case Study #2 - Project Analysis

Charlotte Matthews, Vice President of Sustainability for RELATED ([www.related.com](http://www.related.com)), reported at the Greenbuild® International Conference and Expo in Chicago, November 2010 ([www.greenbuildexpo.org](http://www.greenbuildexpo.org)), that their building's total energy consumption would decrease by 3.5% (alternatively, the whole building energy performance would increase by 3.5%) due to the hybrid heat pump system, and that the hybrid system helped them (the developer and the project) receive additional economic incentives such as tax deductions and points/credits under today's green building and government programs.



---

---

# Benefits of Hybrid Heat Pump Systems

---

---



# Overview

There are many benefits to utilizing a hybrid heat pump system including:

- low operating costs
- low sound levels
- ease of maintenance
- simplicity of operation
- reliability
- design flexibility
- ease of installation, and
- better heating comfort.

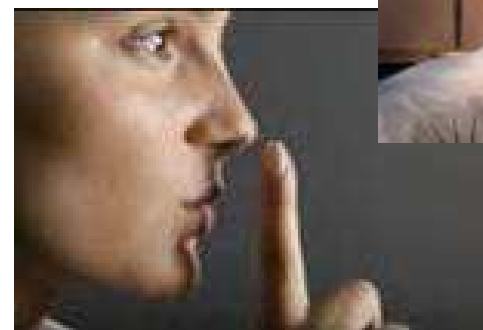



# Energy

The “waste” heat that is reclaimed and reused is a large contributor to the reduced energy consumption of the hybrid heat pump system. Reclaiming and using all of the “waste” heat has a very significant impact. By not operating the compressor in the heating mode, there is a significant reduction in the electrical consumption.

The hybrid heat pump unit is specifically designed to operate with very high energy efficiency ratios (EERs). One main factor is the unidirectional flow of the refrigeration cycle. This enables the unit to be optimized for only one mode of operation, and the evaporators are never called upon to operate as condensers, and vice-versa. The shell and tube condenser effectively rejects energy, but it also enables mechanical, efficient cooling with elevated fluid temperatures.

 Please remember the **exam password ENERGY**. You will be required to enter it in order to proceed with the online examination.

# Energy

A hybrid heat pump contributes to earning credits under the LEED (Leadership in Energy and Environmental Design) green building certification program by exceeding ASHRAE's minimum EER of 12.0.

With the shell and tube condenser, the unit can operate very efficiently with only 2 gpm per ton. This will also save on pumping energy.

The use of “waste” heat also enables the hybrid system to reduce the amount of heat that is rejected to the fluid coolers, thereby minimizing pumping and fan energy associated with fluid coolers.



# Low Sound Levels

With the compressor turned off in the heating mode, it is no surprise that a hybrid heat pump has low sound levels (only fan coil sound levels), but even with the compressors operating, the hybrid unit is quieter than standard WSHP systems.



# Heating Comfort

To provide better heating comfort, the hybrid heat pump system simply schedules the loop temperature to deliver only the amount of heat that is required. Traditional reversing WSHP units have full compressor operation and deliver the same amount of heat regardless of if it is required or not. A fan coil can simply better match the heating requirements. This is quite beneficial in intermediate seasons when full heat may not be required. In a reversing WSHP system, the compressor delivers full heat and satisfies the thermostat very quickly, causing excessive compressor cycling. This has a tendency to result in wide temperature swings.

In addition, the hybrid system operates at a low fan speed for the first 10 minutes, then if required, the fan goes to full speed. This method provides a more gradual temperature rise.



# Reliability

Not only does the hybrid heat pump unit greatly reduce the compressor total run hours of the system, but equally important, the amount of compressor cycling is greatly diminished, which extends its service life.

A particular benefit to schools, hotels, and assisted living spaces is that the heating mode will never be interrupted by failed compressors, since they are not required for the hybrid heat pump to provide heat.



# Installation Cost Savings

Since hybrid units do not operate the compressors in the heating mode, which is the most difficult mode of operation, there may be cases where lower connected electrical load/MCAs (minimum circuit amps) are justified, which in turn results in smaller electrical infrastructures.

Installation costs are reduced because:

- smaller pipes, pumps, and heat exchangers are possible with only 2 gpm/ton as opposed to 3 gpm/ton
- the use of reclaimed heat may remove the need for a separate high temperature water heating loop, as well as the need for gas heating in the make-up-air units
- smaller fluid coolers are possible due to the high efficient condenser design, and
- risers and cabinets are shipped loose for the vertical stack, allowing for a one-person installation.



---

---

# Applications

---

---

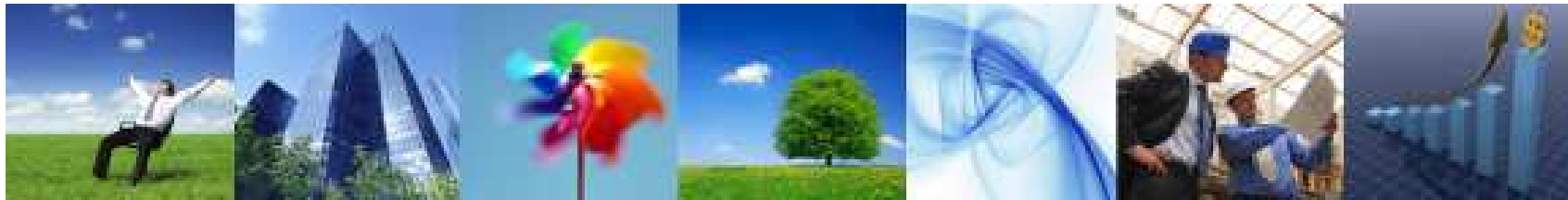

# Condominiums



One of the greenest buildings in America, The Riverhouse, Manhattan, NY, has 1000 hybrid heat pumps.



The new Yorkville Tower, Toronto, ON, construction project consists of one 36-story and one 12-story residential condominium above one floor of retail space. It has 495 hybrid heat pumps and 6 hybrid heat pump make-up-air units. The findings indicated that using traditional heat pumps would demand an increase in the fluid cooler, piping systems, pumping stations and primary electrical service.



A 60-story Manhattan condominium and apartment complex, presently in construction with expected completion in 2012, will utilize 1700 hybrid units.



# Office Buildings



The Bell Canada Office Campus, Montreal, QC, consists of approximately one million square feet of Class “A” office space.



The Ontario Power Generation Nuclear Support Building, Pickering, ON, received the Canadian Design-Build Institute’s First Place Award of Excellence. Hybrid heat pumps and make-up-air units were placed in central mechanical rooms for easy future maintenance. Low operating costs are a result of exceeding minimum energy standards, which qualified the project for the Canadian Federal Government’s Commercial Building Incentive Program.

# Schools & Assisted Living Centres



Langdon Elementary School, Langdon, AB, consists of 41 horizontal hybrid units with a 2-pipe heat recovery loop, utilizing a dry-type fluid cooler for heat rejection and a hot water gas fired boiler for heat injection. The units are controlled by a computerized building management system.

The annual savings on this project are projected at \$22,000 annually (over \$536 per unit per year), not including additional pump horsepower savings due to a 25% reduction in required flow, which affected the size and installed cost of all central system components.



The Sunrise Assisted Living center, Mississauga, ON, required a way to ensure heating under a loss-of-power condition. A back-up generator was required, and size of the generator and power distribution were considerations. A hybrid heat pump system was selected to provide year-round heating and air conditioning, utilizing a 2-pipe heat recovery loop with an auxiliary boiler and cooling tower. The installation cost was similar to a water source heat pump system, but the energy cost was reduced by 35-40% annually. This project featured hinged access doors with magnetic strips allowing easy filter service. Removal of the access panels reveal service LEDs and a sight glass for troubleshooting, but the entire chassis is plug-connected for quick change-out in 15 minutes. One spare chassis can serve the entire project.

# Hotels & Resorts



Delta Vancouver Airport Hotel,  
Vancouver, BC



Holiday Inn, Sea Tac, Seattle, WA



With its wide variety of building uses, the Westin Trillium House, The Village at Blue, Blue Mountain, ON, created opportunities to make use of “waste energy” in the form of useful energy. Utilizing a hybrid heat pump system, the banquet areas heat the rooms which in turn heat the pool, which conditions the common areas at different times of the year. The Aqua Centre was then tied into the loop, utilizing waste energy from humidity in pool area, further increasing efficiency. Considering the aesthetic requirements, non-intrusive make-up-air was installed in vertical and horizontal floor mounted units in the common areas.

# Historic Buildings



The Ellis Building on Adelaide Street, Toronto, ON



The restoration of this nine-floor, century old skyscraper, Broad Street Bank, Trenton, NJ, required an HVAC retrofit. Preserving the historic nature of the building required a system with a small footprint. Low electrical consumption was a priority, due to the limitations of the available services and the need for greater efficiency. A hybrid heat pump system with its retrofit- friendly design proved to be the perfect choice for this historic restoration. The low profile horizontals were concealed in the ceilings, and console units were surface mounted with little intrusion on the aesthetic value of the interior. An efficient central heating plant, with its unique heat recovery system, services the entire building. The ultra quiet, super efficient system raised the comfort level of the building, while meeting and exceeding their energy requirements.

---

---

# Hybrid Heat Pump Geothermal Systems

---

---



# Introduction

A variation of the hybrid heat pump system has been applied to geothermal systems. Since the compressors do not operate in heating mode, a method of removing the heat from the ground is required. Water-to-water chillers are used for this purpose. Substantial energy savings are realized in the intermediate seasons by turning off the heating compressors when there is sufficient heat in the loop, similar to the closed loop system.

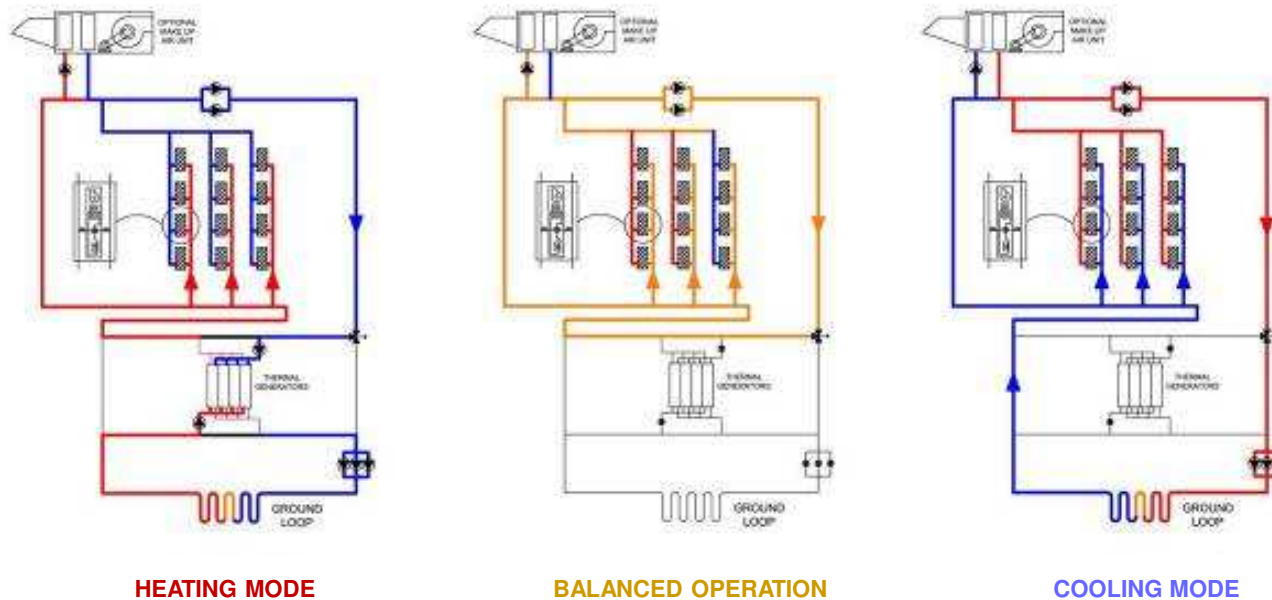

# Cooling Mode

During the cooling mode, the hybrid system is identical to a reversing system. The water cooled AC units extract heat from the occupied space and reject this heat, along with the heat of compression, to the fluid loop. This total heat of rejection is delivered to the ground loop, which acts as a heat sink.

The heat stored in the ground during the cooling season will be used as a heat source in the heating season.

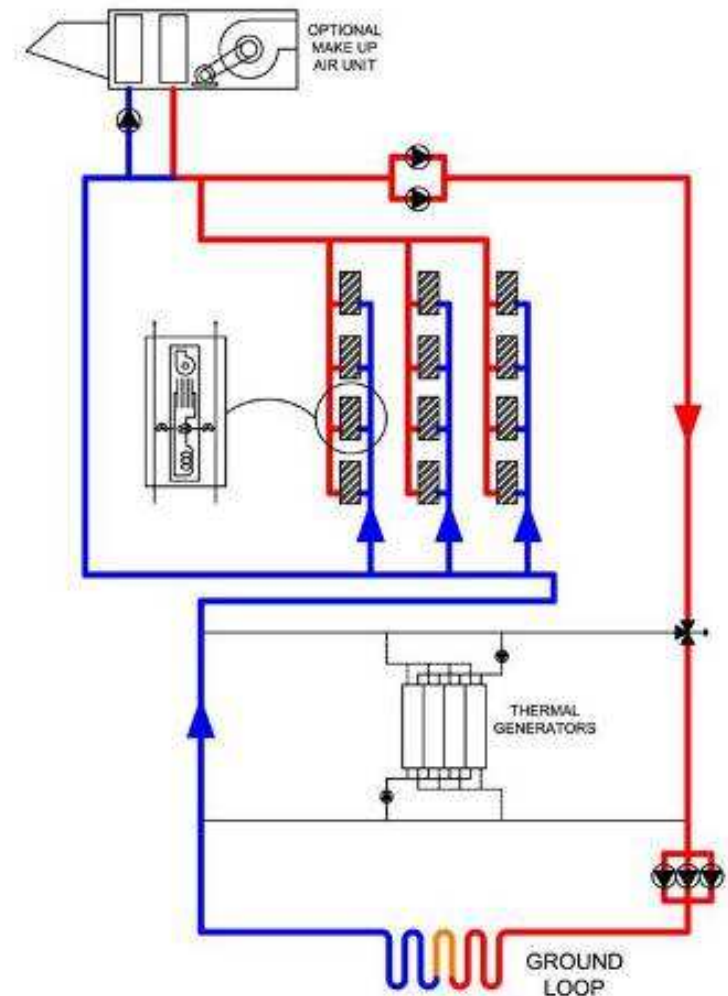

COOLING MODE

# Balanced Operation

Balanced operation occurs when heat needs to be neither rejected nor extracted to the geo loop. In this mode, there is sufficient heat in the fluid loop from the heat of rejection of the cooling units to directly satisfy the heating requirements. Heat can simply be transferred from the cooling zones to the heating zones.

The one major difference associated with the hybrid system is that the heating units do not need to operate compressors in order to absorb the heat from the fluid loop. Considerable electrical savings are realized this way. The hybrid system in this mode may also transfer less heat to the geo loop, which may reduce the size of the geo field, as well as minimize the amount of heat transferred to the ground.

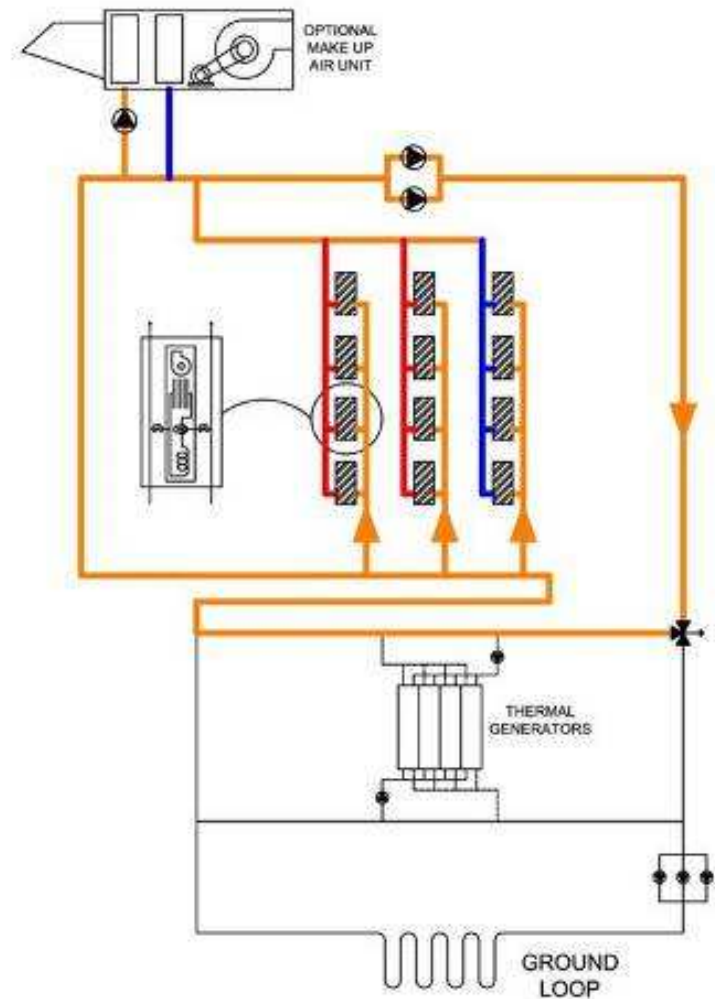

**BALANCED  
OPERATION**



# Heating Mode

In the heating mode, fluid is circulated through the building interior heat pump loop and also through the geothermal loop. Because the hybrid heating units do not operate compressors, heat extraction from the geothermal loop is provided for by water-to-water heat pumps.

The evaporators extract heat from the ground and transfer this heat, along with the heat of compression, to the condenser fluid. This warm fluid is delivered to hydronic heating coils located in the hybrid heat pump. This is quite different from traditional reversing systems that rely on evaporator fluid from the ground loop to deliver the heat to the heat pumps.

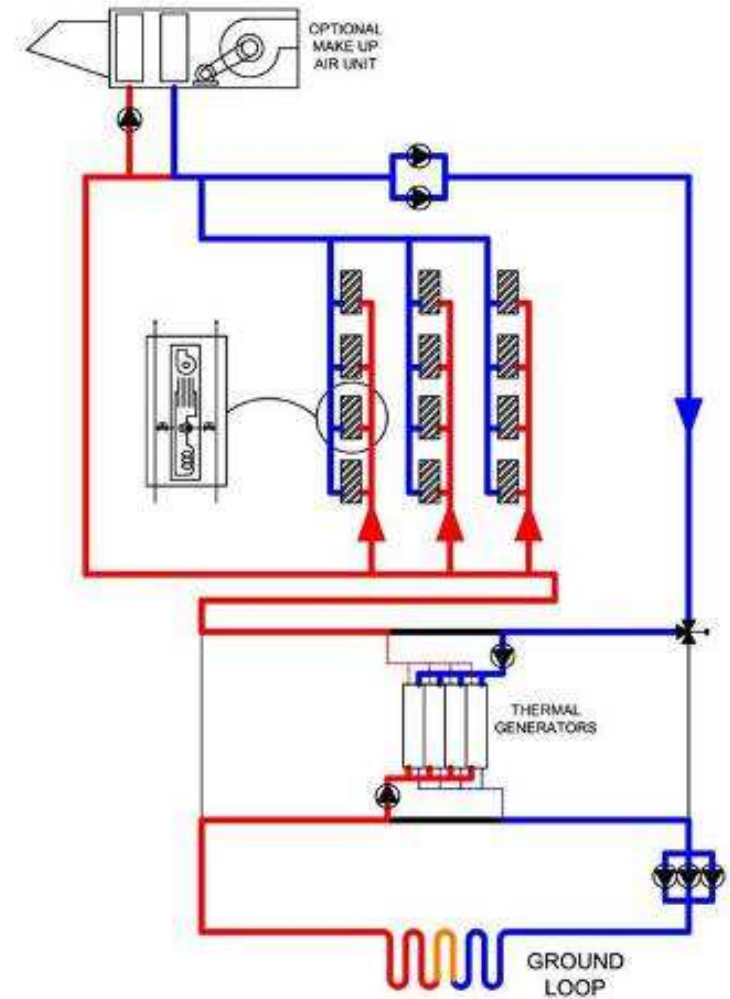

HEATING MODE

# Heating Mode

With the traditional WSHP unit, the evaporator fluid can be quite cold, and therefore the pipes have to be insulated. With a hybrid system, the pipes do not need to be insulated since the fluid is actually warm condenser fluid.

The water-to-water heat pumps are only staged to the instantaneous load, as opposed to a traditional reversing system which operates all the heating compressors, regardless of how much heat is actually required. Therefore, the hybrid system minimizes electrical consumption.

In order to deliver sufficient heating in geothermal applications in a cold climate, the heat pumps of a traditional reversing system may be oversized. This is due to the relatively low operating pressures, which reduce the amount of heat that can be provided. With the hybrid system, regular sized units are used since they operate as standard fan coils.

# Total Removal of Stored Heat

The hybrid system has another advantage over traditional reversing systems, since it operates on the principle of warm fluid for heating purposes. The water-to-water heat pumps can extract more heat from the ground loop, and then make this heat available for a wide variety of uses throughout the entire building. This keeps the ground loop from overheating, and also ensures total removal of the stored heat in order to return the earth to a heat sink condition.

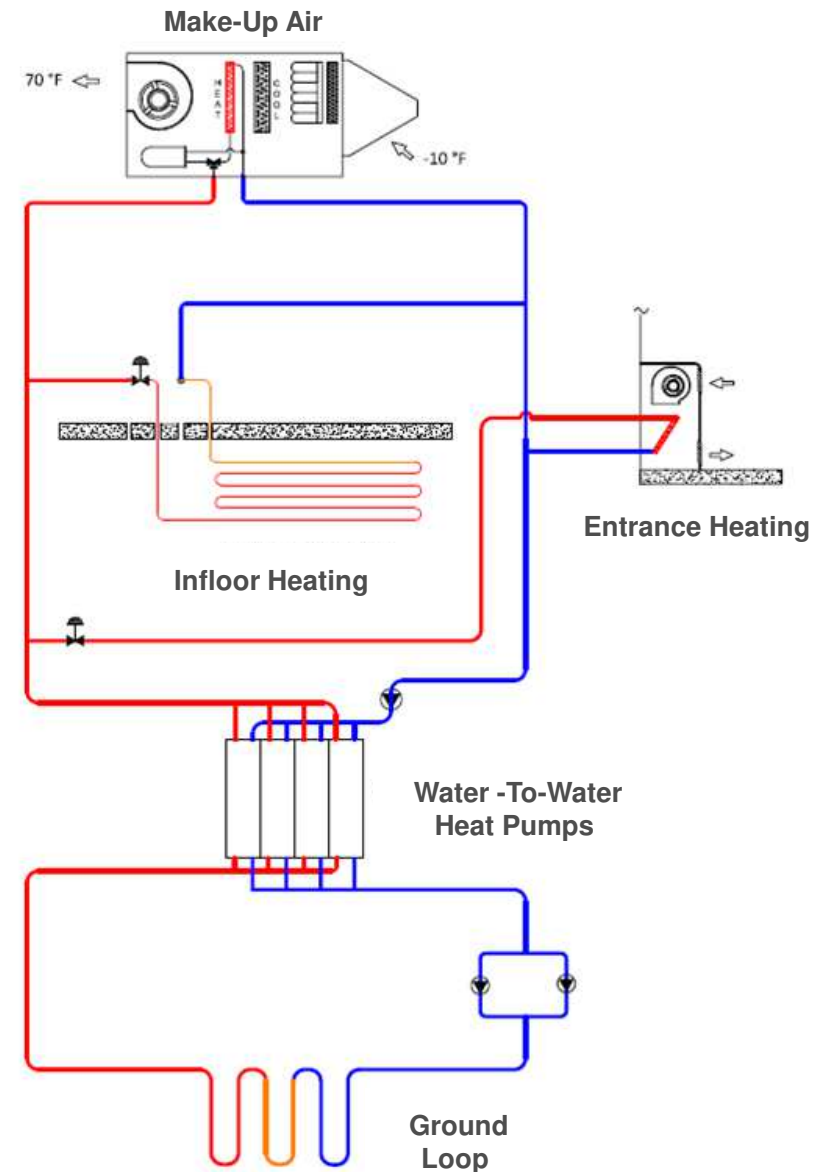

# Applications



In Montréal, QC, the Le Vistal condominium buildings are located on the tip of L'Île-des-Sœurs. These two 25-story towers were built with the comfort of the residents and eco-friendly practices in mind, so an energy efficient system was needed. Among the ecologically conscious systems and materials installed were 330 hybrid heat pumps, 14 water-to-water heat pumps, and R-410A refrigerant. The use of these systems allowed Le Vistal to participate in the Green Loan program, whose loans are repaid with the money that energy-smart designs save. Since Le Vistal was designed to achieve LEED certification, these buildings continue to aim for the highest standards in environmental sustainability and efficient operation.



An independent analysis by Caneta Energy ([www.canetaenergy.com](http://www.canetaenergy.com)) confirms that a hybrid heat pump geothermal system installed in the Springdale Professional Building, Brampton, ON, will result in 23.8% energy savings over a conventional WSHP system.

System type	HVAC only (Annually)		Entire Building (Annually)	
	Energy Use (kWh)	Operating Costs (\$)	Energy Use (kWh)	Operating Costs (\$)
Conventional GSHP	619,963	\$55,169	1,577,827	\$143,056
Hybrid heat pump	472,309	\$43,311	1,430,280	\$131,198
<b>Savings</b>	<b>147,654 (23.8%)</b>	<b>\$11,858 (21.5%)</b>	<b>147,547 (9.4%)</b>	<b>\$11,858 (8.3%)</b>

# Conclusion of This Program

If you desire AIA/CES, state licensing or CE credits for another organization, please click on the button to commence your online examination. A score of 80% or better will allow you to print your Certificate of Completion; you may also go to your AEC Daily Transcript to see your completed courses and certificates.

For additional knowledge and post-seminar assistance, click on the Ask an Expert link above.

If you have colleagues that might benefit from this seminar, please let them know. Feel free to revisit the AEC Daily website to download additional programs from the Online Learning Center.

 [MORE](#)



©2011, 2014 CGC Group Inc. The material contained in this course was researched, assembled, and produced by CGC Group Inc. and remains its property. "LEED" and related logo is a trademark owned by the U.S. Green Building Council and is used by permission. Questions or concerns about the content of this course should be directed to the program instructor. This multimedia product is the copyright of AEC Daily.

[Click Here to Take the Test](#)

Exit

powered by  [www.aecdaily.com](http://www.aecdaily.com)