



Drainage: Vertical and Horizontal Building and Sitework Applications



Building science experts acknowledge the need for drainage in both vertical and horizontal applications in order to eliminate moisture issues and extend the life of the building. This course examines foundation wall, green roof, and plaza deck applications and discusses the factors that impact drainage, including soil permeability, saturation, land cover, and loading. Flow rate standards are discussed, and drainage composite mat installation is explained.

COURSE INFORMATION

-  **Association Approvals**
-  **How to Use This Online Learning Course**
-  **Purpose and Learning Objectives**

COURSE

☰ Drainage Applications

☰ Water Drainage

☰ Flow Rate Testing

☰ Drainage Composite Installation

THANK YOU

☰ Thank You



This Online Learning Seminar is available through a professional courtesy provided by Advanced Building Products, Inc.

©2022 Advanced Building Products, Inc.

Association Approvals

AIA

The American Institute of Architects

Course No. AEC1739-01

This program qualifies for 1.0 LU/HSW Hour

Course Expiry Date: 02/21/2028

AEC Daily Corporation is a registered provider of AIA-approved continuing education under Provider Number J624. All registered AIA CES Providers must comply with the AIA Standards for Continuing Education Programs. Any questions or concerns about this provider or this learning program may be sent to AIA CES (cessupport@aia.org or (800) AIA 3837, Option 3).

This learning program is registered with AIA CES for continuing professional education. As such, it does not include content that may be deemed or construed to be an approval or endorsement by the AIA of any material of construction or any method or manner of handling, using, distributing, or dealing in any material or product.

AIA continuing education credit has been reviewed and approved by AIA CES. Learners must complete the entire learning program to receive continuing education credit. AIA continuing education Learning Units earned upon completion of this course will be reported to AIA CES for AIA members. Certificates of Completion for both AIA members and non-AIA members are available upon completion of the test.



**Approved
Continuing
Education**

RCEP

AEC Daily Corporation has met the standards and requirements of the Registered Continuing Education Program. Credit earned on completion of this program will be reported to RCEP at RCEP.net. A certificate of completion will be issued to each participant. As such, it does not include content that may be deemed or construed to be an approval or endorsement by the RCEP.



How to Use This Online Learning Course

Scroll through the content to progress through each chapter and, at the end of the content, click the numbered arrow to advance. Or, use the sidebar to navigate between chapters and track your progress.

Within this course is a  **password** that you will need to proceed with the online test. Make sure to have it ready at the end of the course.

To receive a **certificate** indicating course completion, refer to the instructions at the end of the course.

For **additional information** and postseminar assistance, click on the buttons or links below.

ABOUT THE INSTRUCTOR

[CLICK HERE](#)

ABOUT THE SPONSOR

[CLICK HERE](#)

ASK AN EXPERT

[CLICK HERE](#)

COURSE DETAILS

[CLICK HERE](#)

Purpose and Learning Objectives

Purpose:

Building science experts acknowledge the need for drainage in both vertical and horizontal applications in order to eliminate moisture issues and extend the life of the building. This course examines foundation wall, green roof, and plaza deck applications and discusses the factors that impact drainage, including soil permeability, saturation, land cover, and loading. Flow rate standards are discussed, and drainage composite mat installation is explained.

Learning Objectives:

At the end of this program, participants will be able to:

- identify vertical and horizontal drainage applications,
- summarize factors that impact drainage rates, such as soil permeability and saturation, impervious surfaces, and land cover,
- recall vertical and horizontal loading calculations for foundation walls, green roofs, and plaza decks,
- describe flow rate testing standards as per ASTM D4716, and
- discuss installation methods for drainage composite mats for foundation walls.

Drainage Applications

Applications for Drainage Composite Mats

Today, there are many different applications in buildings where a drainage composite mat can and should be used.

A drainage composite mat consists of parallel geometric drainage channels backed with nonwoven filter fabric designed to eliminate hydrostatic pressure from vertical and horizontal applications, including below-grade foundation walls, retaining walls, and planters.



Commercial Applications for Vertical Drainage

Commercial applications, including high-rise buildings, require drainage composite mats on foundation walls; they are often used in combination with blindside waterproofing (waterproofing systems are installed before the foundation walls are built) and with lagging (earth retention) walls.

Additional uses for drainage composite mats include retaining walls commonly found in highway projects, bridge abutments, tunnels, underground parking garages, and commercial planters.



Residential Applications for Vertical Drainage

Vertical drainage mats can be used for residential projects, including basement walls, retaining walls, and planters.



Commercial Applications for Horizontal Drainage

Drainage composite mats can also be used for horizontal commercial applications, including plaza decks, patios, balconies, and vegetated green roofs. A plaza deck provides areas for greenspace planting and vehicular or pedestrian movement. Using a supported split slab construction, plaza decks are often over occupied spaces.



Split Slab

Split slab construction is shown in the image to the right. The first layer is called the topping slab.

The second layer is the drainage composite, which is installed directly above the waterproofing layer.

Below the waterproofing layer is the structural slab.

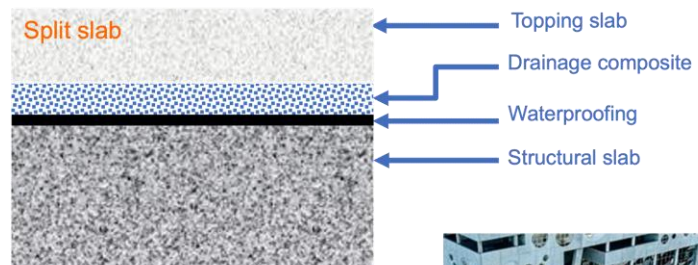

Split slab construction is commonly used for plaza decks, sports facilities, assembly concourses, airport roadways, and parking structures.



Under Slab

Drainage composite mats are also used for under-slab construction. This type of drainage is used in projects with a lot of groundwater and provides water drainage from under the slab on grade.

In the top image on the right, the first layer is the concrete slab, followed by the vapor barrier. The following layers include the drainage composite and then the aggregate base.

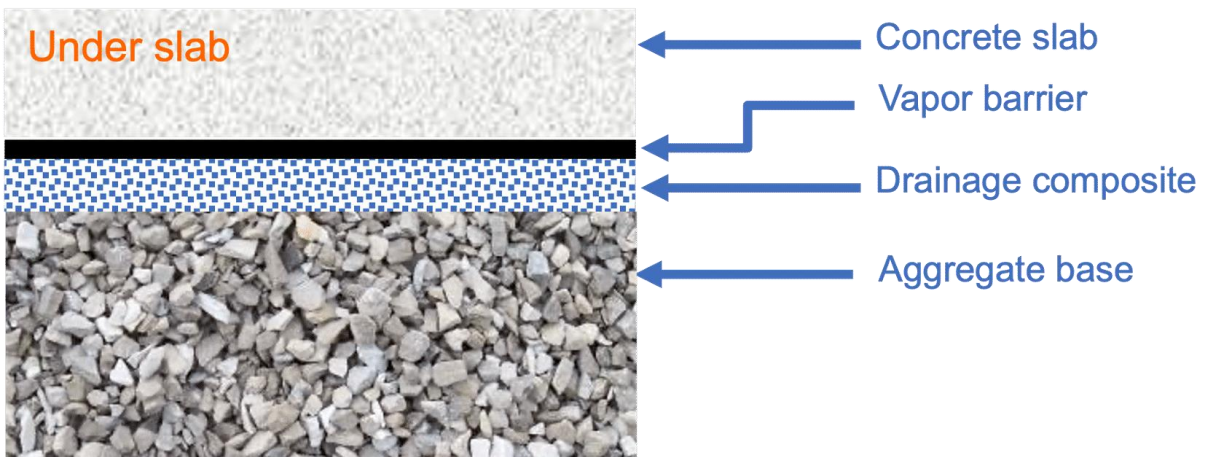

Residential Applications for Horizontal Drainage

Horizontal drainage is used in residential projects, including yard drainage. Low areas, as seen in the image on the lower left, are difficult to drain. In these situations, a drainage mat with filter fabric on both sides can be laid below grade on a slope. A perforated pipe can then be guided to a gravel-filled trench to carry the water away to daylight or a below-grade drainage structure.

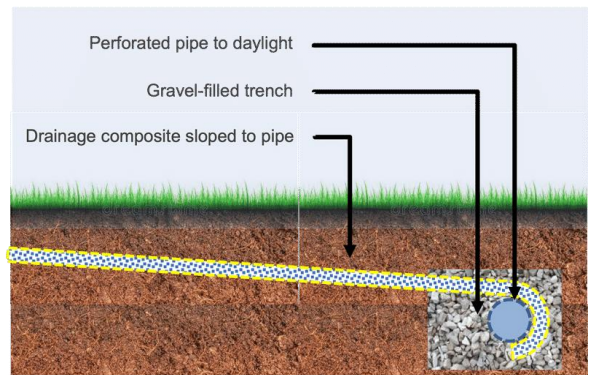
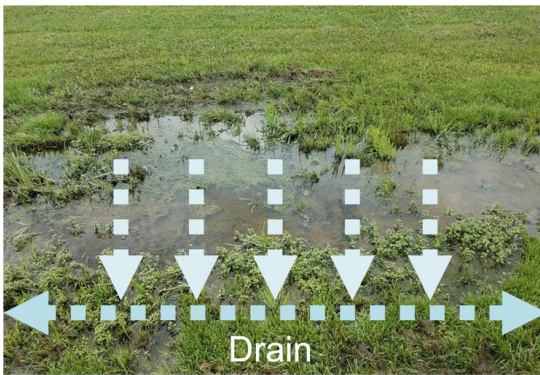

Athletic Applications for Horizontal Drainage

Horizontal drainage can also be used in athletic projects. For example, golf courses need drainage in teeing areas and sand traps. Natural and synthetic turf fields also require drainage to maintain a dry, playable area.

Horizontal drainage mats can be used under playgrounds to prevent wet areas that make them unpleasant or unusable.

Creating a pet yard amenity is becoming more common in large city condominium projects. These green areas have introduced a new application for pet turf drainage.

Pet turfs typically use synthetic turf over a drainage composite mat that allows the turf to be hosed down to prevent odors or unsanitary conditions.



Considerations for Drainage Composites

There is a lot of misinformation about drainage requirements in the construction industry. Below are some things to consider during the planning stages. Consult your manufacturer, architect, or engineer for further details about how drainage composites can enhance your project.

How much water needs to drain?

How much load is typical?

Is compressive strength necessary?

Does routine lab testing reflect actual field conditions?

How is the capacity (flow rate) of a drainage mat measured?

Can real-world conditions restrict the capacity?

In the next section, water drainage is discussed.

Water Drainage

How Much Water Reaches a Subsurface Drainage Composite?

Let's consider how much water reaches a subsurface drainage composite. The first thing to look at is the possible water amounts created by rainfall. Second, the potential water amounts are affected by the infiltration of the water into the soil and by the permeability of the ground. The last thing that affects how much water reaches the drainage composite is the soil pressure or the load applied to the drainage composite that can affect its capacity.

Potential Water Based on Rainfall

This map shows the rainfall amounts in each part of the US. The rainfall rates are based on the greatest amount of rain recorded that has fallen in five minutes.

You can see that the worst-case scenario in the United States is in the southeastern coastal areas, where they have received 7.8 inches per hour. All the other parts of the country have rates lower than 7.8 inches.

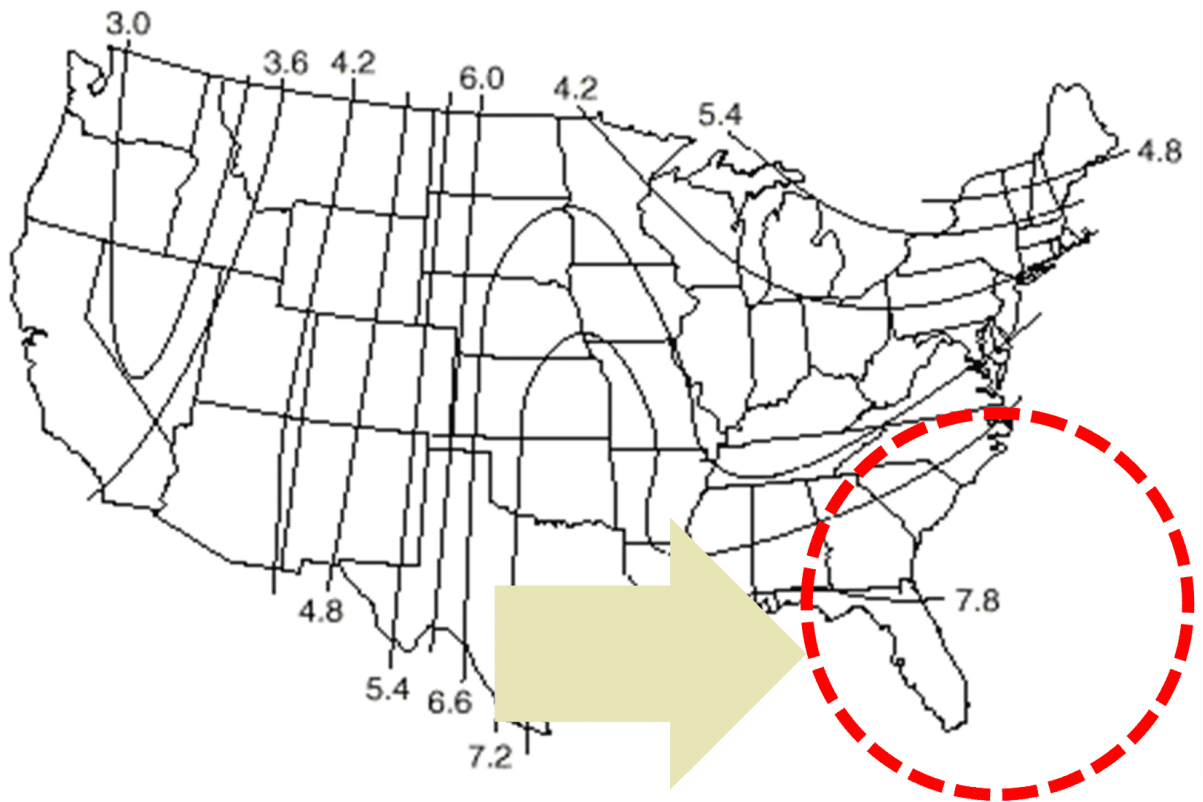

So how do we translate that rainfall data? The 7.8 inches per hour is based on a 10-year storm. However, a worst-case storm could double that amount of water up to 15.6 inches per hour. That would be the worst-case rainfall for the entire country.

Now we will do some conversions. First, we will convert inches per hour to cubic inches per hour. Multiply the depth of 15.6" x 12" x 12". The result is 2,246 cubic inches per hour. Then we will convert cubic inches per hour to cubic feet per hour. This calculation works out to approximately 1.3 cubic feet per hour.

Next, if we multiply the cubic feet per hour by 7.48, that will convert to 9.72 gallons per hour. The last calculation converts from gallons

per hour to gallons per minute. Divide 9.72 gallons per hour by 60, resulting in 0.162 gallons per minute.

This means that there could be approximately 0.162 gallons of rain falling every minute in a worst-case rainfall situation.

Drainage Mats and Rainfall

Drainage mats are constructed to handle increased water flow. A thin drainage mat that allows flows at only 5 gallons per minute per foot of width can accommodate 30 times the amount of water that a worst-case scenario would produce. In comparison, if you look at a thick drainage mat, it can accommodate 170 times the amount of water that a worst-case scenario would produce.

Next, we will look at some other factors that affect the amount of water reaching the drainage composite.

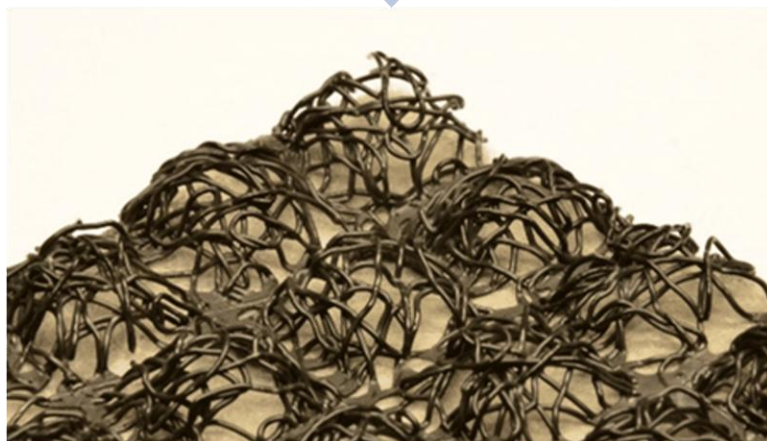
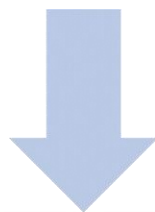

Infiltration and Soil Permeability

Water infiltration and soil permeability both affect how much water reaches a drainage composite. Permeability refers to how well water can flow through the soil. Rainfall is the fastest infiltrating form of precipitation. If more rain falls than can infiltrate the soil, it simply runs off. Interestingly, very light and slow rain penetrates the soil more than a quick, hard storm.

Soil porosity determines the amount of water infiltration you have into the soil or how much space there is in the soil to hold water. Soil with a very small pore size—for example, clay—has a lower infiltration capacity than soils that have a large pore size, such as sand.

Also, the compaction of the soil has a direct effect on porosity. Typically, the greater the soil compaction, the lesser the porosity.

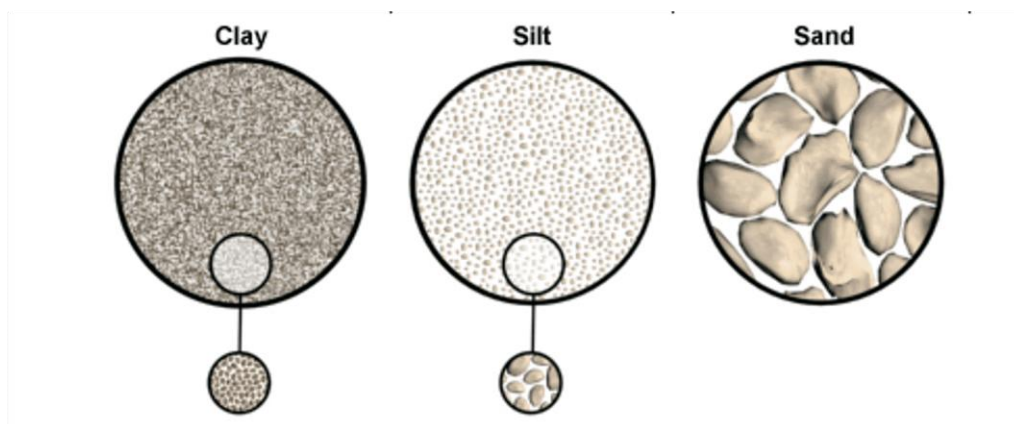

Soil Saturation

Soil saturation can also affect the amount of water that reaches the drainage composite.

Saturated soil cannot hold water, so when the soil is saturated, the extra water runs off instead of draining into the ground.

The amount of organic material in the soil can affect infiltration. The roots of plants and tiny tunnels that animals and insects create make cracks and fissures in the earth, increasing water infiltration and permeability, thus allowing water to soak in.



Permeable and Impermeable Surfaces

We've talked about the soil itself, but what about the land cover? If impermeable surfaces cover the property or the site of the building (for example, asphalt, concrete, or impervious pavers), no water infiltration will occur. Instead, water will run off the surface directly into nearby storm drains or oceans, rivers, or lakes.

The slope also impacts the amount of infiltration. The steeper the pitch around the building, the less infiltration into the soil; this means you will have more runoff.

The amount of infiltration decreases with an increase in the slope.



Land Cover and Infiltration

This table gives some quantifiable data on how land cover affects infiltration. From left to right, there is the percentage of ground cover, runoff, evapotranspiration, and the amount of both shallow and deep infiltration into the soil.

If there is only natural groundcover, there will be a low amount of runoff—approximately 10%, with 40% of the water lost to evapotranspiration. The infiltration into the soil is 50%. As the impervious cover increases, you can see how the runoff also increases while evapotranspiration and water infiltration decrease.

The land cover significantly affects how much water reaches your drainage composite through infiltration.

Ground Cover	Runoff	Evapotranspiration	Infiltration	
			Shallow	Deep
Natural	10%	40%	50%	
			25%	25%
10% to 20% Impervious	20%	38%	42%	
			21%	21%
35% to 50% Impervious	30%	35%	35%	
			20%	15%
75% to 100% Impervious	55%	30%	15%	
			10%	5%

Loads: Vertical Applications

Let's look at loading for vertical drainage composite applications—for example, a below-grade wall. To determine the load, we will calculate the soil earth pressure, where $P_a = H \times K \times \gamma$

P_a = The active earth pressure in lb/ft²

H = Height of the wall in ft

K = Coefficient of earth pressure

γ or gamma = Unit weight of soil* in lb/ft³

*Unit weights of soils range from 90 to 120 lb/ft³

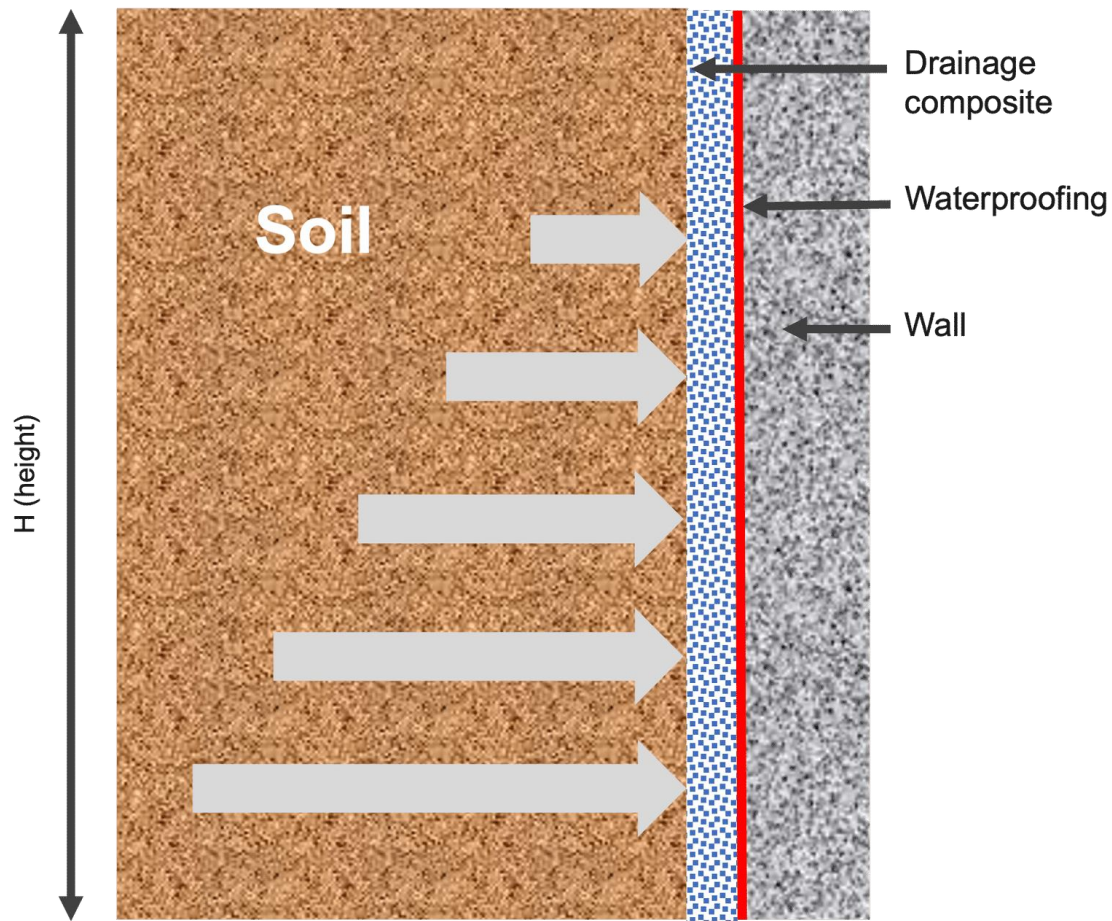

The drawing above shows that the deeper the wall is below the finished grade, the greater the pressure exerted against the foundation wall. Pressure is determined at any point along the wall by adjusting the height.

For this example, the wall height is 35 feet, and the soil type is a clayey-sand mixture.

$$P_a = H \times K \times \gamma$$

$$P_a = 35 \times 0.42 \times 100 \text{ lb/ft}^3$$

*Unit weights of soils range from 90 to 120 lb/ft³

$$P_a = 1,470 \text{ lb/ft}^2$$

Different soil types affect the pressure exerted against the drainage composite and wall. Sand-based soils exert less pressure, while clay soils increase the pressure on the wall.

Soil Type	Coefficient (K)
Sand	0.25
Silty Sand	0.33
Clayey Sand	0.42

Soil Type	Coefficient (K)
Sandy Clay	0.56
Silty Sand	0.67
Clay	0.83

Soil Types

Soils, in general, are essentially mixtures of sand, silt, and clay. Many projects may already include soil borings, which will tell you what kind of soil you have. A local geotechnical company can advise you about the type of soil found near your project.

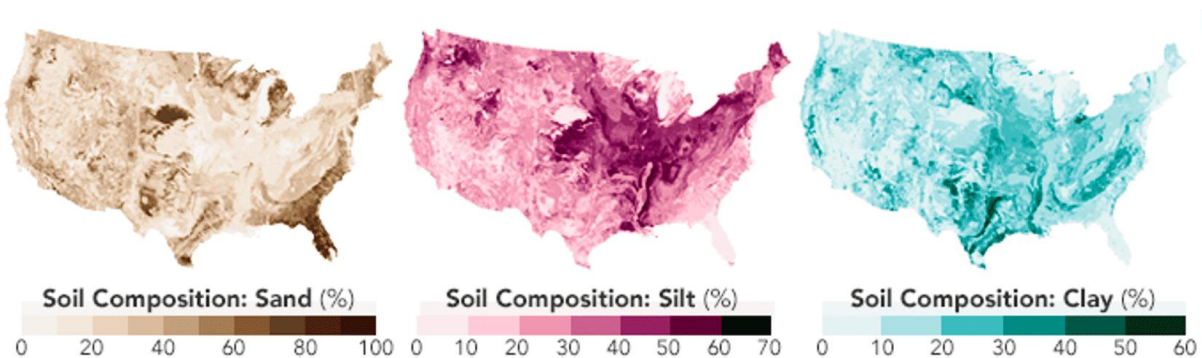

Loads: Horizontal Applications

Next, we look at loads for horizontal applications such as roofs or plaza decks. The calculation for horizontal applications is $P_a = T \times \gamma$

P_a = The active earth pressure in lb/ft^2

T = Thickness of soil/cover in ft

γ or gamma = Unit weight of soil* in lb/ft^3

*Unit weights of soils range from 90 to 120 lb/ft^3

For this example, 3 feet of soil times 100 lb/ft^3 equals 300 lb/ft^2 .

Now add the maximum live load as per the *International Residential Code* (IRC) and *International Building Code* (IBC), which is 100 lb/ft^2 (assembly occupancy); you would have a total load of 400 lb/ft^2 .

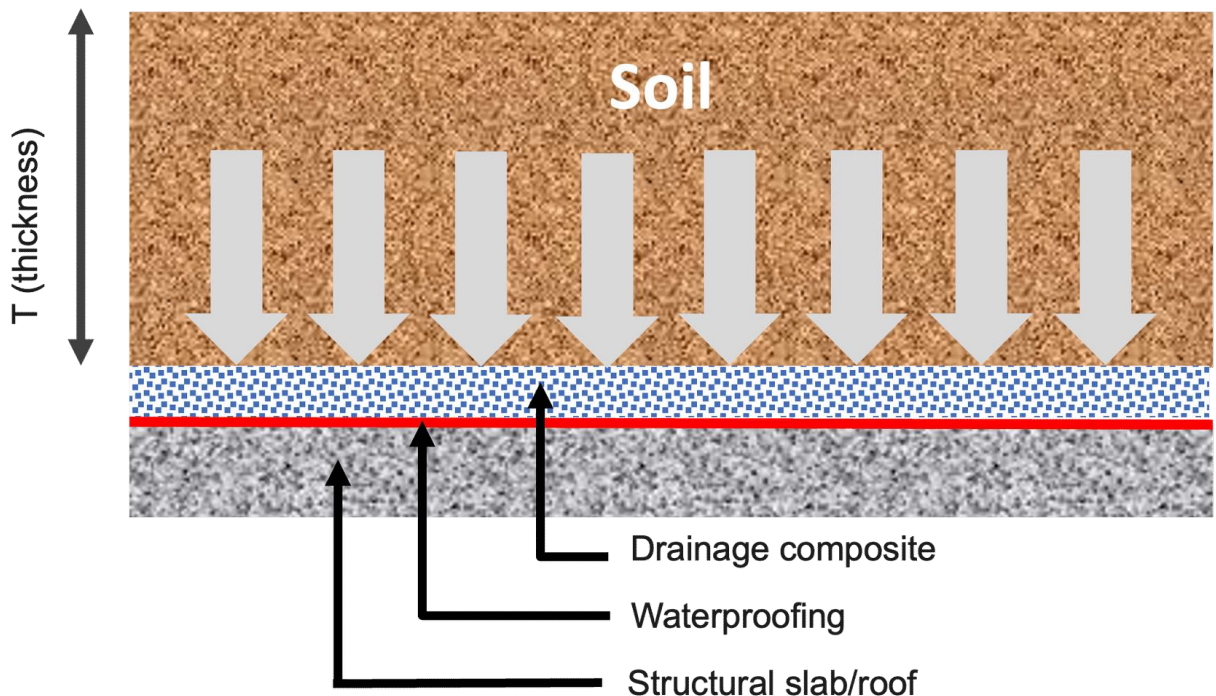

Typical Horizontal Loads

Here are several typical examples of horizontal loads and the potential pressure exerted on the drainage composite. In the left table, you can see the amount of pressure exerted on the drainage composite from the 2-inch concrete, a snow load, and a live load. You can see the additional pressure from a 4-inch concrete slab in the right table.

2" Concrete Topping Slab over Drainage Composite

Load	Pressure	
	Low	High
Snow load	0 psf*	160 psf*
Live load	40 psf*	50 psf*
2" Concrete	25 psf	25 psf
Total load	65 psf	235 psf

4" Concrete Topping Slab over Drainage Composite

Load	Pressure	
	Low	High
Snow load	0 psf*	160 psf*
Live load	40 psf*	50 psf*
4" Concrete	50 psf	50 psf
Total load	65 psf	260 psf

*International Building Code requirements

Here you have a 2-inch extensive green roof over a drainage composite, with a snow load, a live load, vegetation, and 2 inches of growing media. Total weights can range from 112 pounds per square foot to 275 pounds per square foot. Next, on the table on the right, you have a 4-inch extensive green roof over a drainage composite with a snow load, a live load, vegetation, and 4-inch growing media. This total weight can range from 123 pounds per square foot to 288 pounds per square foot.

2" Extensive Green Roof over Drainage Composite

Load	Pressure	
	Low	High
Snow load	0 psf*	160 psf*
Live load	100 psf*	100 psf*
Vegetation	1 psf	2 psf
2" Growing media	11 psf	13 psf
Total load	112 psf	275 psf

4" Extensive Green Roof over Drainage Composite

Load	Pressure	
	Low	High
Snow load	0 psf*	160 psf*
Live load	100 psf*	100 psf*
Vegetation	1 psf	2 psf
4" Growing media	22 psf	26 psf
Total load	123 psf	288 psf

*International Building Code: 100 psf live load based on highest assembly occupancy

The next assembly is a 6-inch extensive green roof over a drainage composite, including a snow load, a live load, vegetation, and 6-inch growing media. The total weight can range from 134 pounds per square foot to 301 pounds per square foot. On the right, you have a 36-inch intensive green roof over a drainage composite with a snow load, a live load, vegetation, and 36 inches of growing media. The total weight can range from 340 pounds per square foot to 548 pounds per square foot.

6" Extensive Green Roof over Drainage Composite

Load	Pressure	
	Low	High
Snow load	0 psf*	160 psf*
Live load	100 psf*	100 psf*
Vegetation	1 psf	2 psf
6" Growing media	33 psf	39 psf
Total load	134 psf	301 psf

36" Intensive Green Roof over Drainage Composite

Load	Pressure	
	Low	High
Snow load	0 psf*	160 psf*
Live load	100 psf*	100 psf*
Vegetation	5 psf	15 psf
36" Growing media	235 psf	273 psf
Total load	340 psf	548 psf

*International Building Code: 100 psf live load based on highest assembly occupancy

Compressive Strength

Typically, 3,600 pounds per square foot compressive strength is the maximum encountered.

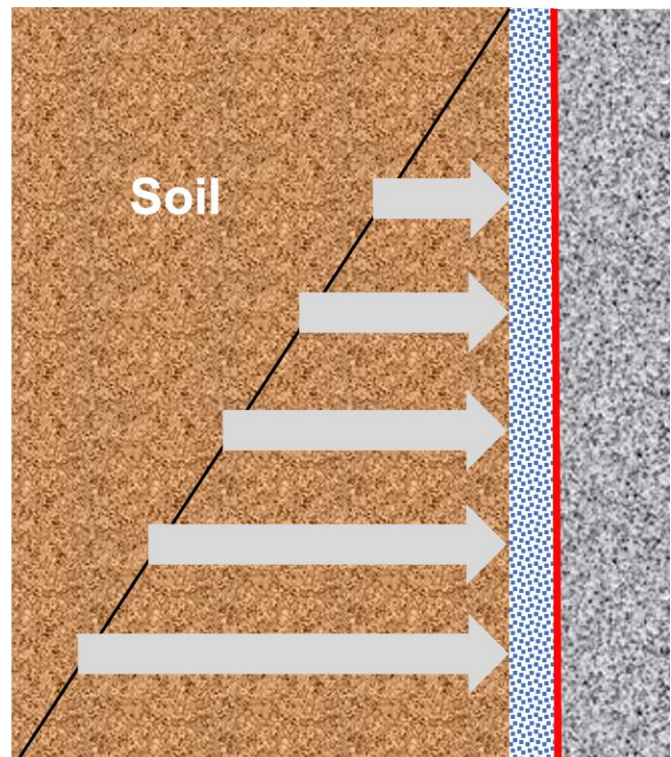

Review Question

Label the diagram and explain where this type of construction would be used.

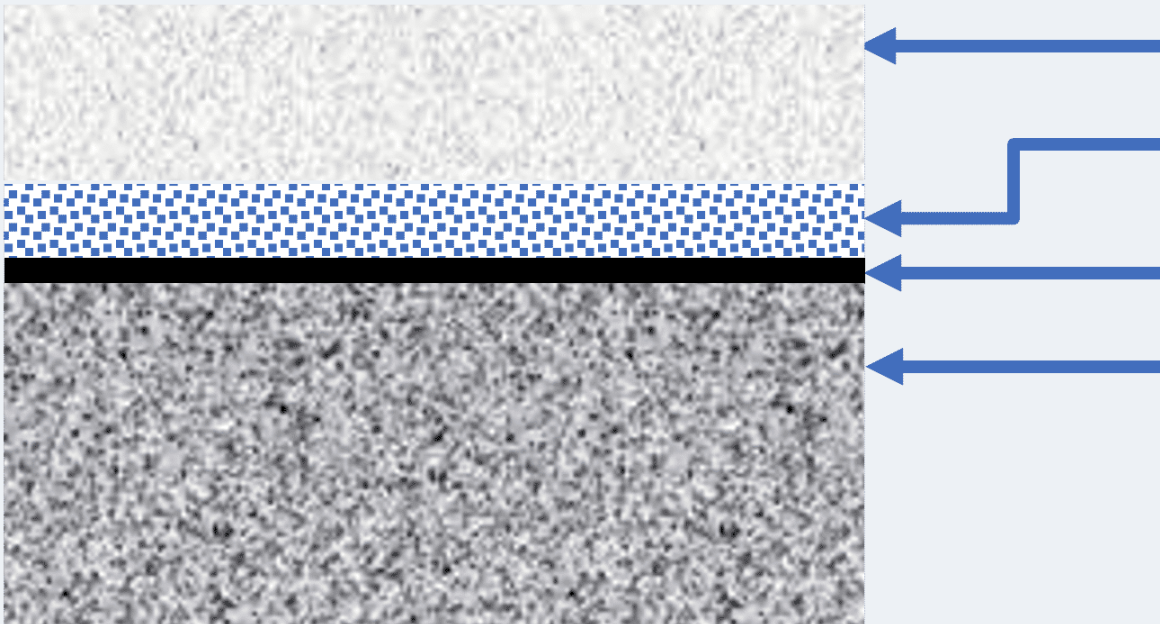

Answer

Split slab construction is commonly used for plaza decks, sports facilities, assembly concourses, airport roadways, and parking structures.

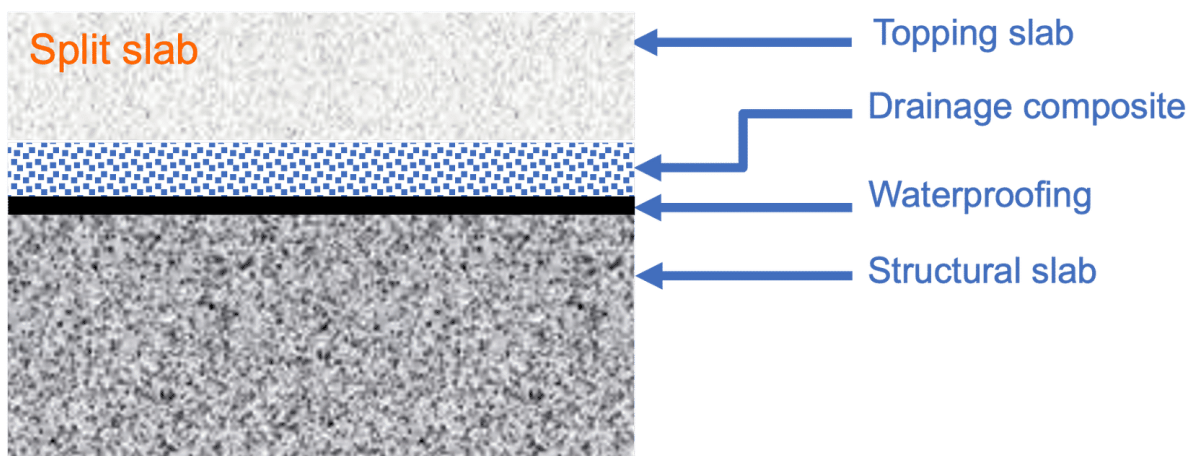

Flow Rate Testing

Testing for Flow Rate per ASTM D4716

Drainage testing for flow rates is typically done using ASTM D4716. This test standard allows and recommends different types of platens that can be used to reflect real-life conditions. A neoprene or foam platen most closely simulates soil and is used by many labs. The test standard also allows you to test the platen with soil on it. Many manufacturers in the industry test using two steel platens because that gives them the highest flow rates. Using two hard platens ignores a problem caused when soil presses against the drainage composite, called geotextile fabric intrusion. This intrusion into the drainage core reduces the flow rate of the drainage composite. Below, you can see the actual wording from the ASTM D4716 standard.

ASTM D4716, "Standard Test Method for Determining the (In-plane) Flow Rate per Unit Width and Hydraulic Transmissivity of a Geosynthetic Using a Constant Head."

Section 8.1.2

For performance testing, the nature of the material in contact with

the geosynthetic in the field should be modeled. A rigid platen on one or both sides of the specimen simulates similarly rigid surfaces (such as concrete walls or stiff geomembranes) where intrusion into the geosynthetic openings or pore spaces is not anticipated. Where intrusion is expected, as is the case for a geotextile in contact with soil or a geonet/geotextile/soil section, a layer of rubber membrane* or representative soil may be placed between the platen and the geosynthetic specimen.

*Neoprene rubber is typically used.

ASTM D4716 measures the in-plane flow of the drainage composite. It is also called in-plane permeability.

Typical installation of a drainage composite mat is with one side against a rigid surface (a wall or a slab) and the other facing the soft soil.

ASTM D4716 measures the gallons of water that pass through a 1-foot-wide section of the drainage composite in one minute. The arrow in the drawing shows the in-plane direction in a cross-section view of the drainage composite mat.

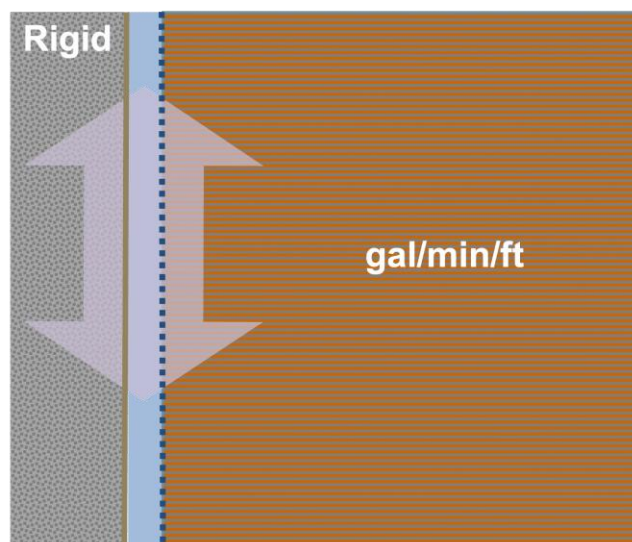

The diagram on the right shows a cross section of a transmissivity tester that is used to test the flow rate of drainage composites.

Looking at item 4, you can see the platens (in red)—one on the top and one on the bottom. They can be made of hard steel or a softer neoprene or foam.

If you test with two hard platens, it doesn't replicate the conditions of a foundation drain, but if you do the test with a steel platen on one side and a softer platen on the other side, it more closely tests the real conditions for a foundation, a plaza deck, or a green roof where you have soil pressing on the drainage mat.

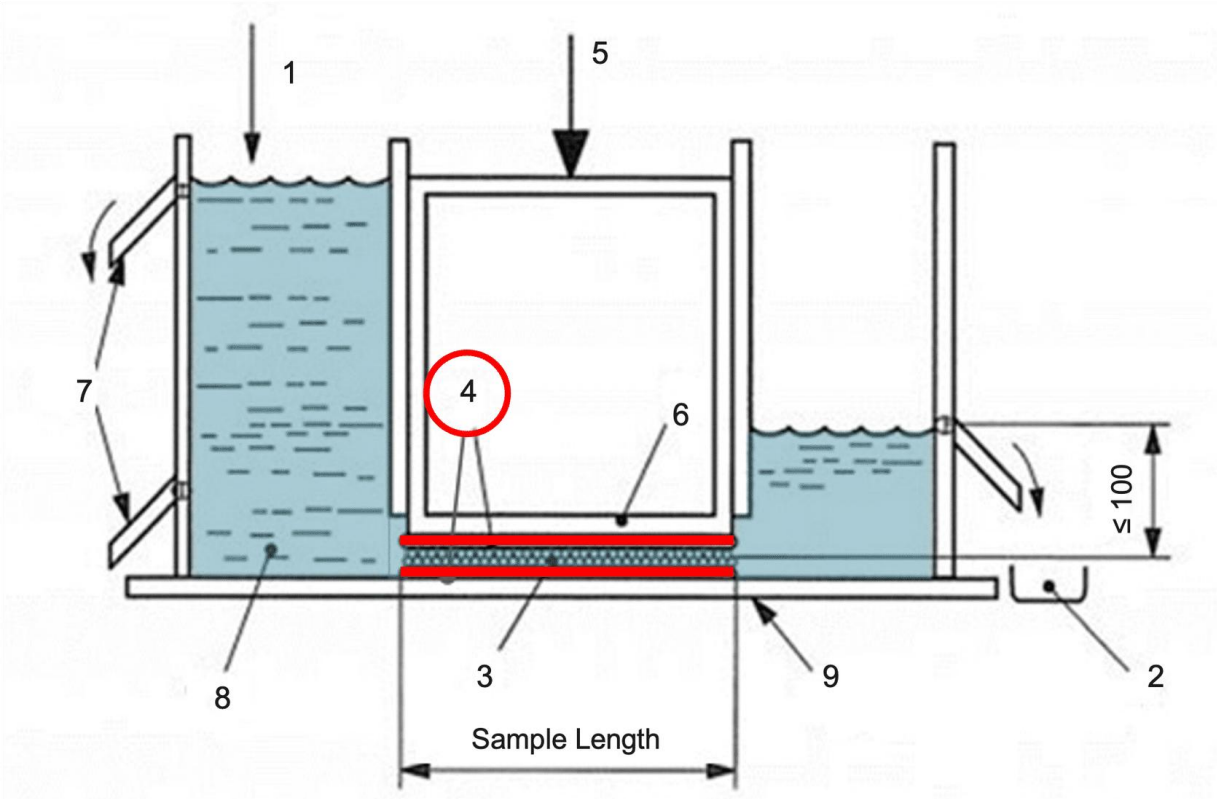

Transmissivity Tester

- | | |
|--------------------------------|--------------------|
| 1. Water supply | 5. Load |
| 2. Water collection | 6. Loading platen |
| 3. Drainage composite specimen | 7. Overflow |
| 4. Platens | 8. Water reservoir |
| | 9. Base |

Geotextile Intrusion May Cause Capacity Restriction

If the geotextile filter fabric is not properly attached to the drainage composite, intrusion of this filter fabric into a drainage composite can cause capacity restriction. The soil presses against the fabric and reduces the amount of space in the drainage core for draining water.

Sometimes the continuous pressure of the soil can pull the geotextile loose, and it can further close off the drainage space.

When you test the products with only hard platens on both sides, intrusion of the fabric never shows up.

But when you test the product using a soft platen on one side that simulates soil, the flow rates of a drainage mat can be reduced by more than 50%.

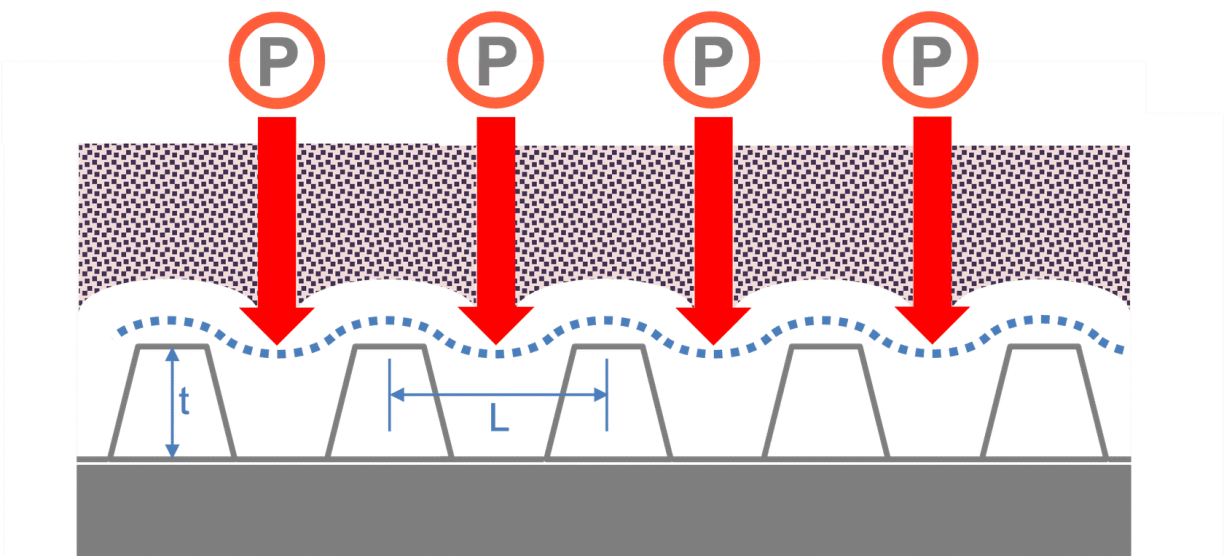

t: thickness of the core

L: distance between the geotextile supporting points

P: soil pressure

Entangled Drainage Composites

To ensure proper drainage in your vertical, horizontal, or below-grade applications, look for entangled drainage composites made from extruded polymer with randomly oriented monofilaments, which are shaped into a series of parallel, porous channels. This design allows for water flow in all directions.

Entangled drainage composites are thermally bonded to a polyester nonwoven filter fabric while the drainage core polymers are still molten, creating a superior bond. This filter fabric will prevent soil or sediment from entering the matrix of the system while providing an ample flow of water.

Entangled drainage composites offer filtration and drainage without the concern of capacity restriction.



An entangled drainage composite mat can be used in many applications, including patio balconies, vegetated roofs, plaza decks, pavers and patios, residential and commercial foundation walls, retaining walls, and planters.

This type of drainage composite offers filtration and drainage all in one. It is lightweight and easy to handle and can be installed in vertical or horizontal directions. Installation is simple and only involves construction adhesive or termination bars. Entangled drainage composite lies flat with no roll memory and easily seams. The drainage composite rolls are easy to cut, and no special cutting tools are required.

Another advantage to using entangled drainage composite is that the polymer cores are resistant to most known solvents and chemicals, including acids and bases.

Entangled Drainage Composite
Water moves through in all directions
Resilient enough to accept loading
Lies flat with no roll memory and easily seams
Easy to cut, safe, with no sharp edges
Resistant to acids and bases
Suitable for vertical, horizontal, and below-grade applications

Review Question

Label the missing parts of the diagram and explain what is important about the ASTM D4716 testing standard.

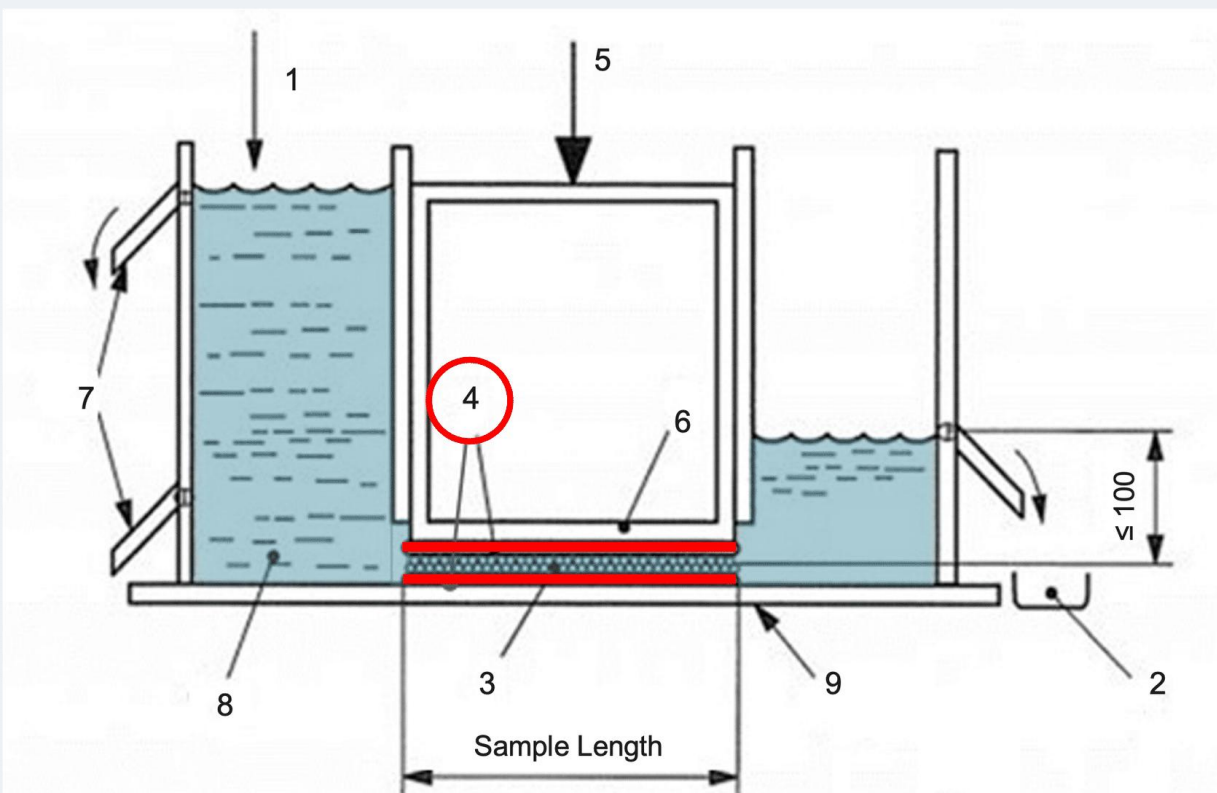

Transmissivity Tester

- | | |
|--------------------------------|-------------------|
| 1. | 5. Load |
| 2. Water collection | 6. Loading platen |
| 3. Drainage composite specimen | 7. Overflow |
| 4. | 8. |
| | 9. Base |

Answer

The diagram shows a cross section of a transmissivity tester that is used to test the flow rate of drainage composites.

Looking at item 4, you can see the platens (in red)—one on the top and one on the bottom. They can be made of hard steel or a softer neoprene or foam.

If you test with two hard platens, it doesn't replicate the conditions of a foundation drain, but if you do the test with a steel platen on one side and a softer platen on the other side, it more closely tests the real conditions for a foundation, a plaza deck, or a green roof where you have soil pressing on the drainage mat.

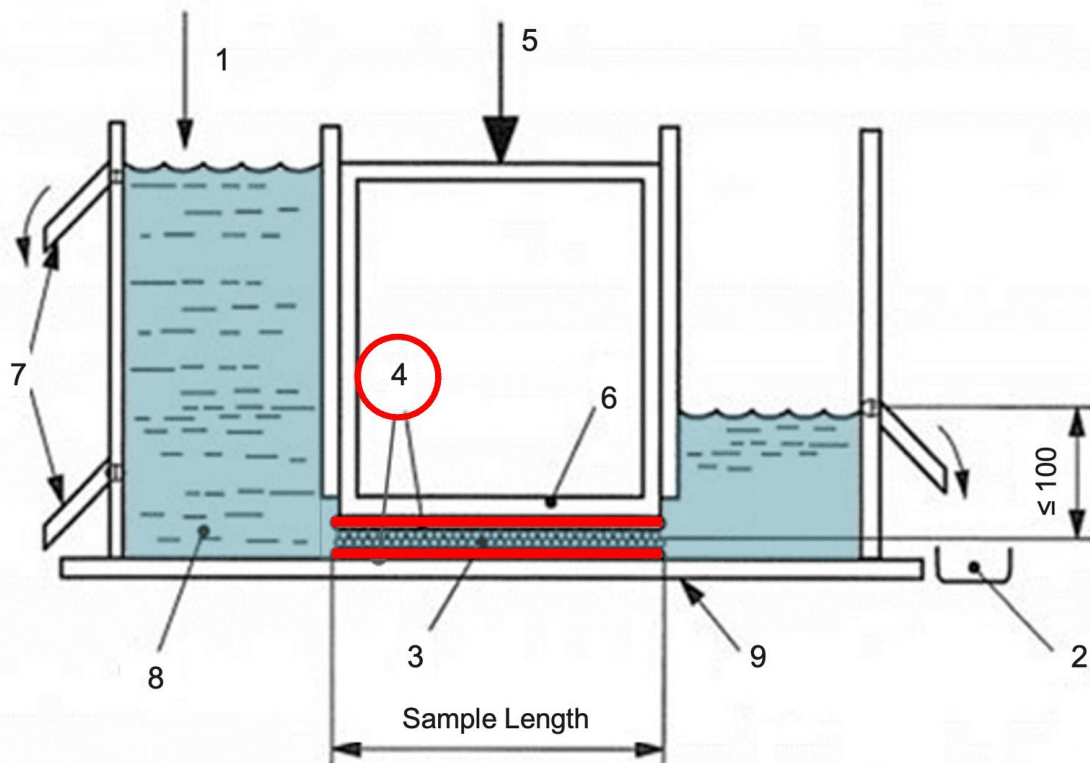

Transmissivity Tester

- | | |
|--------------------------------|--------------------|
| 1. Water supply | 5. Load |
| 2. Water collection | 6. Loading platen |
| 3. Drainage composite specimen | 7. Overflow |
| 4. Platens | 8. Water reservoir |
| | 9. Base |

Drainage Composite Installation

Below-Grade Drainage

We often hear that a foundation drainage system is expensive. This photo shows one ugly fact that, unfortunately, is common: Basements without a proper drainage system leak.

It's an issue for designers, architects, and builders. You can pay now, or you might have to pay big later, with callbacks, complaints, lawsuits, damage to your reputation, and loss of business. It's not that hard to create a dry basement.

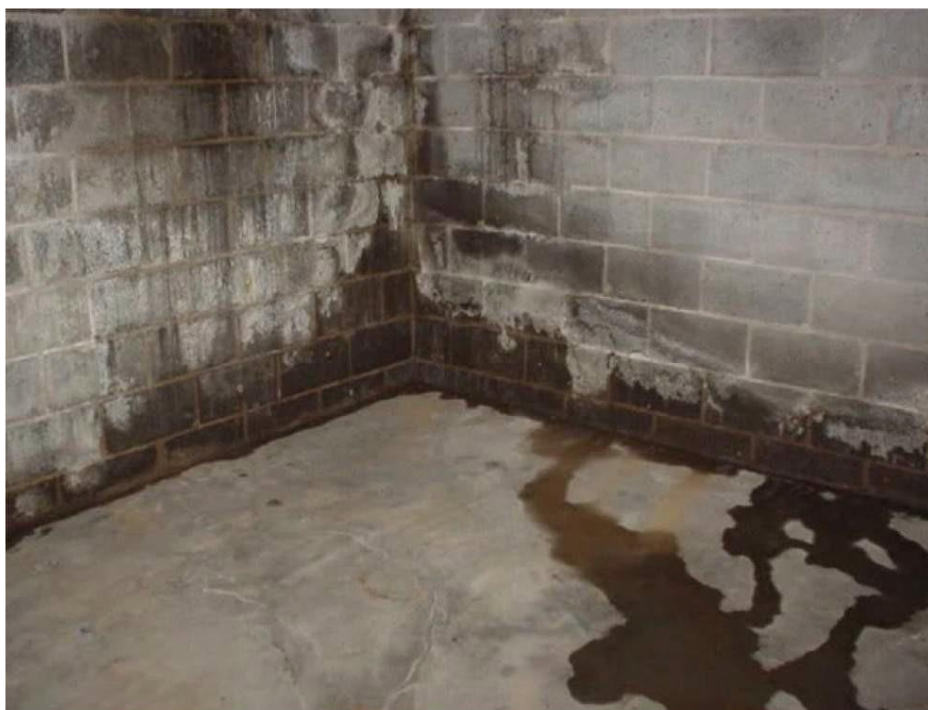

Drainage around Foundations: IBC and IRC Minimums

What do the building codes have to say about the drainage around foundations? The *2021 International Building Code*[®] and the *2021 International Residential Code*[®] require that foundations be positively drained.

Codes require drainage around all concrete and masonry foundations. The codes also include any foundations that retain earth, including foundations that enclose habitable or usable spaces below grade.

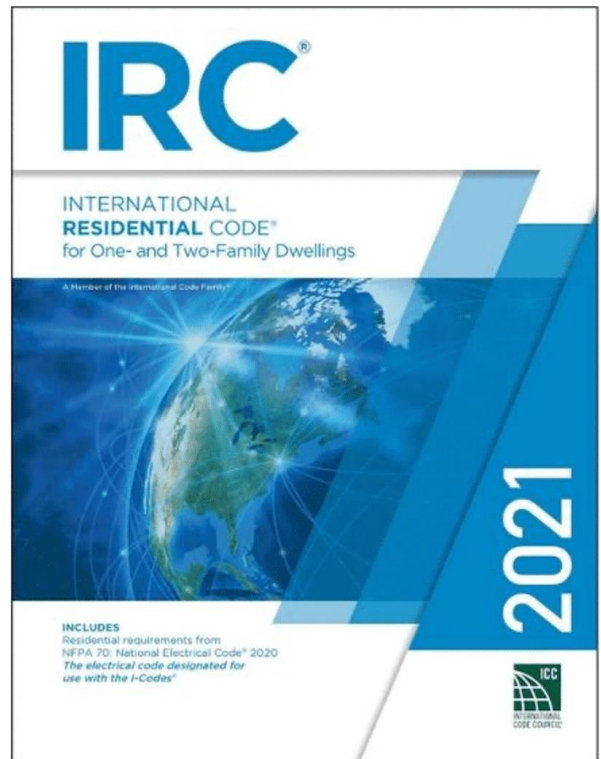
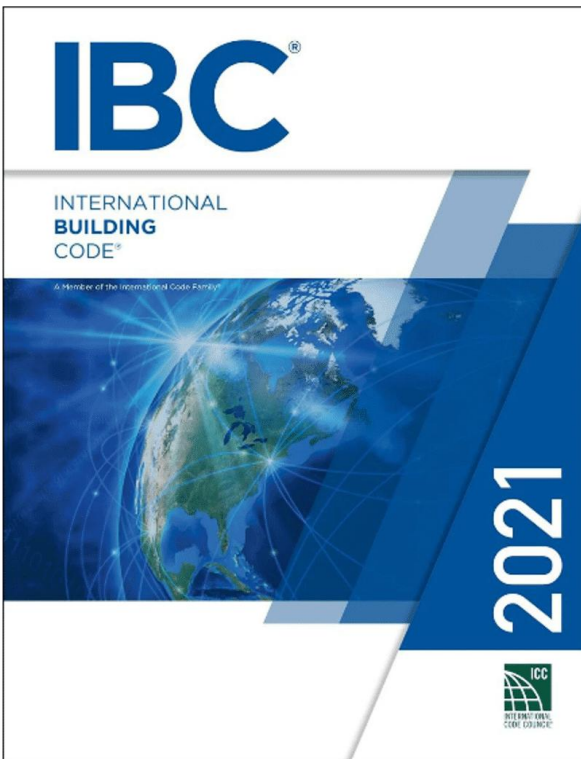

The building codes also says that water can be discharged in two ways. It can be drained by gravity using sloped pipes, or water can be emptied using mechanical means, like a sump pump, to drain.

The discharged water can go into different places—it can drain to daylight where it becomes part of a site surface drainage system or drain to an approved drainage or sewer system, usually a stormwater drain system.

The building codes tell us the minimums that we must meet, but your clients and customers want a dry basement, so what is the best way to achieve that?

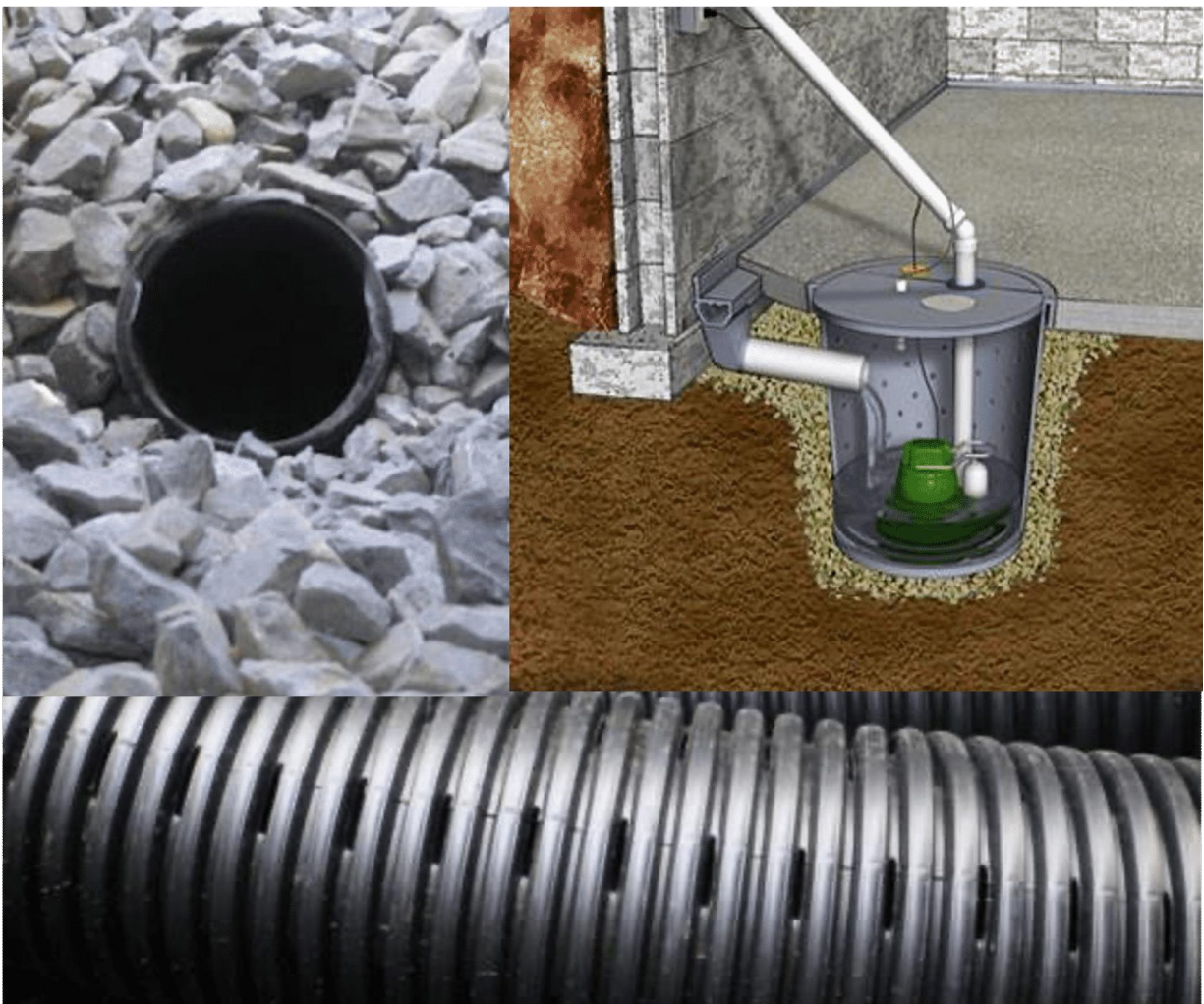

Below-Grade Structures

Here are some of the basics of creating a dry basement.

First, install the perforated perimeter drainpipe, sloping a minimum of a quarter-inch per foot to wherever it's draining.

Then, install the waterproofing or damp-proofing system on the foundation wall. Always follow the manufacturer's recommendations and instructions.

Lastly, install a drainage composite product continuously around the base of the building. The composite is placed just below the finished grade down to the top of the footing and then wrapped around the drainpipe.

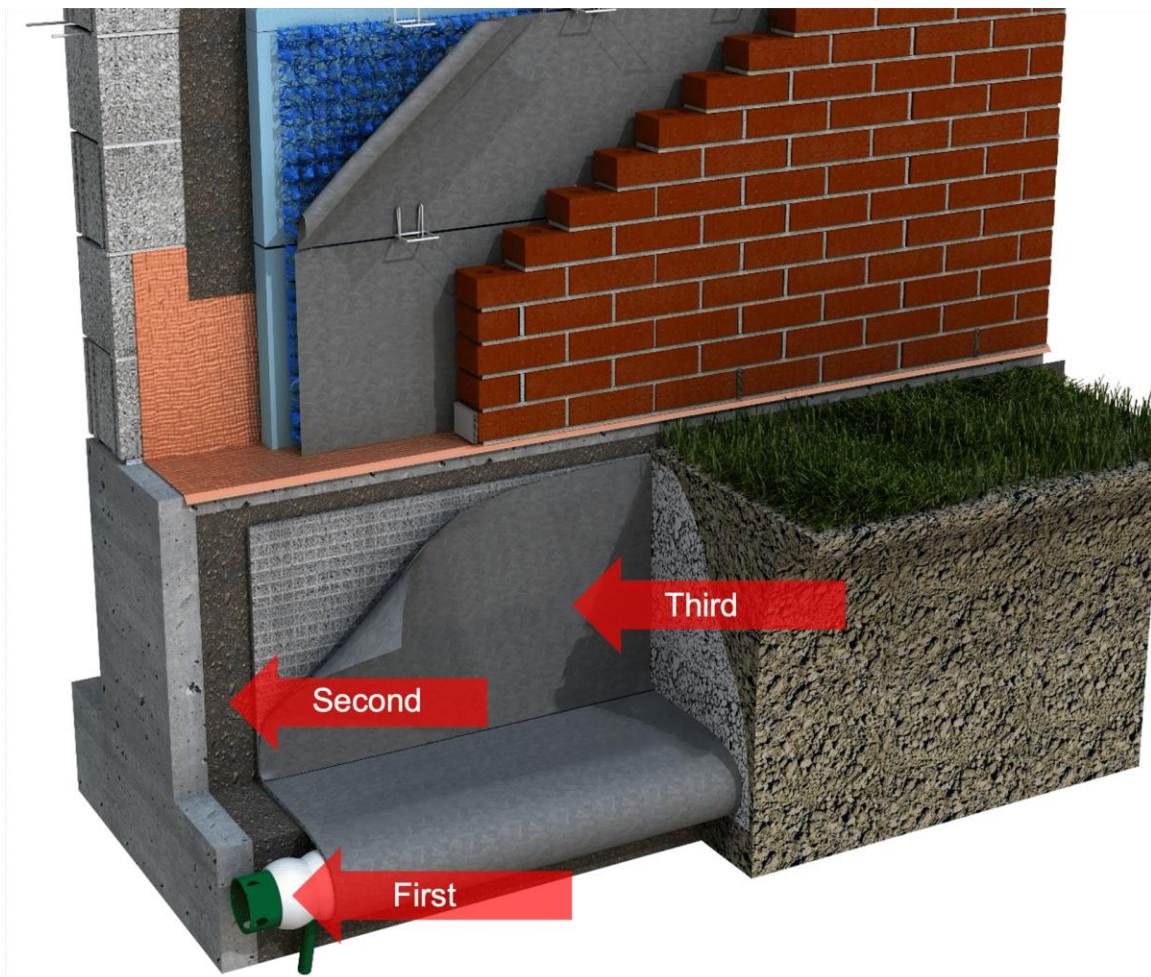

The drainpipe should be in a gravel-filled trench and wrapped in a geotextile filter fabric.

Some drainpipes come with a filter fabric wrap, which would also work. The drainpipe slopes to daylight, or it could connect to a sump pump.

The sump pump should have a battery backup and an airtight cap. The sump pump should pump to an approved drain such as a storm sewer.

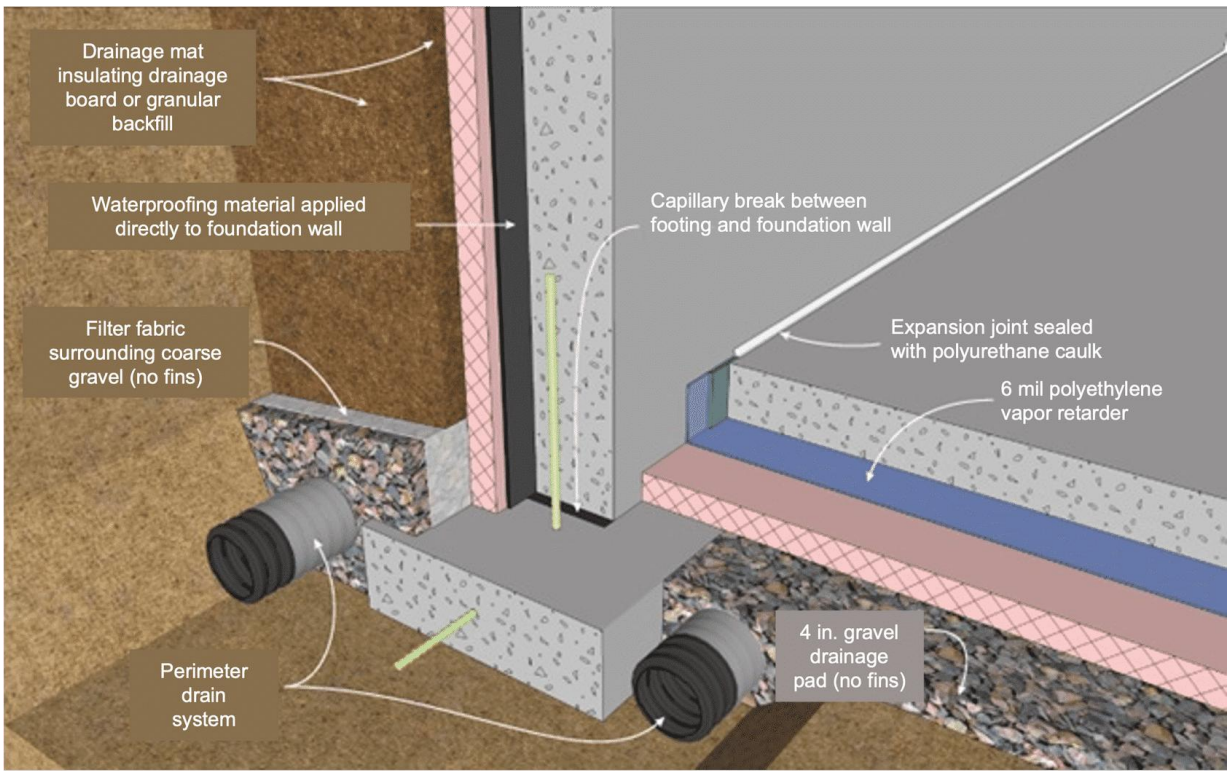

Recommended design detail DOE *Foundation Design Handbook*

Some other things that can help keep the basement dry are to make sure to slope the finished grade away from the foundation wall.

It is good practice to run any gutter downspouts away from the foundation wall by at least 6 feet or tie them into a below-grade drainage system.

One caution is that if you backfill your foundation wall with poor soil like clay, it is going to hold water a lot longer, and it's going to drain more slowly, increasing the potential for water to seep into the foundation. You can cap the backfill with clay to keep surface water away from the foundation.

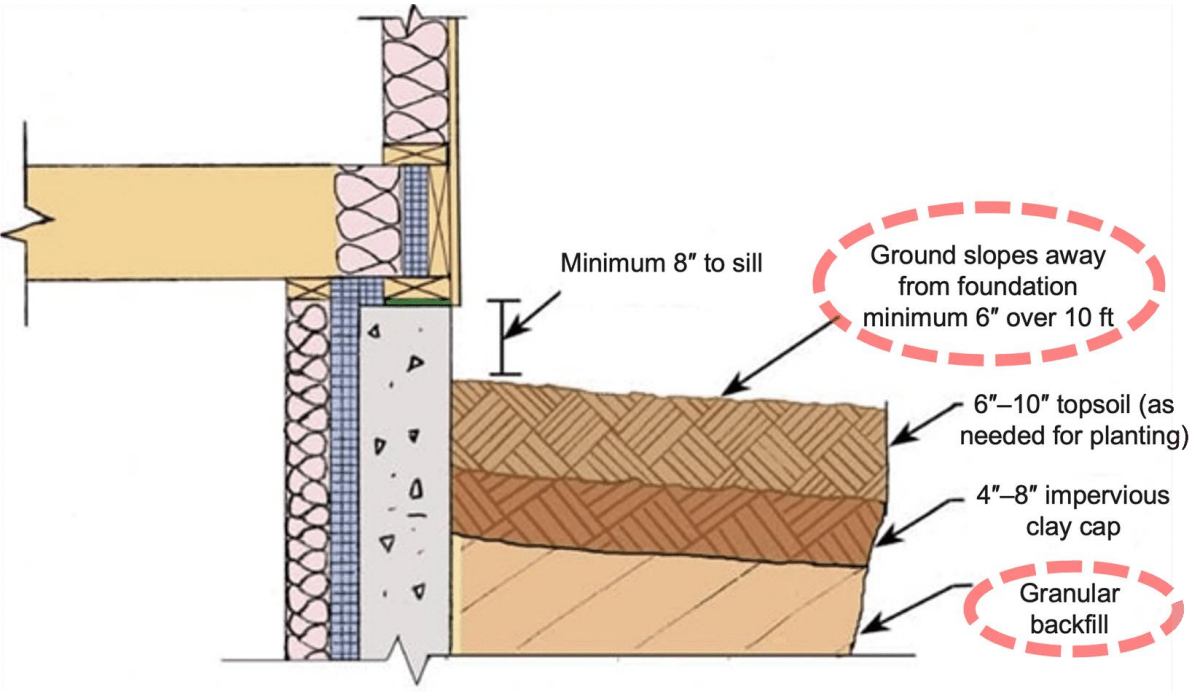

Review Question

Recall the testing standard for drainage flow rate.

Answer —

Drainage testing for flow rates is typically done using ASTM D4716. This test standard allows and recommends different types of platens that can be used to reflect real-life conditions. A neoprene or foam platen most closely simulates soil and is used by many labs. The test standard also allows you to test the platen with soil on it. Many manufacturers in the industry test using two steel platens because that gives them the highest flow rates. Using two hard platens ignores a problem caused when soil presses against the drainage composite, called geotextile fabric intrusion. This intrusion into the drainage core reduces the flow rate of the drainage composite.

Best Practices for Drainage Composite Installation

Here are some best practices for installing a drainage composite.

First, lay the filter fabric in the trench for the drainpipe. Then place gravel in the channel to create the proper drainpipe slope, which is a minimum of a quarter-inch per foot.

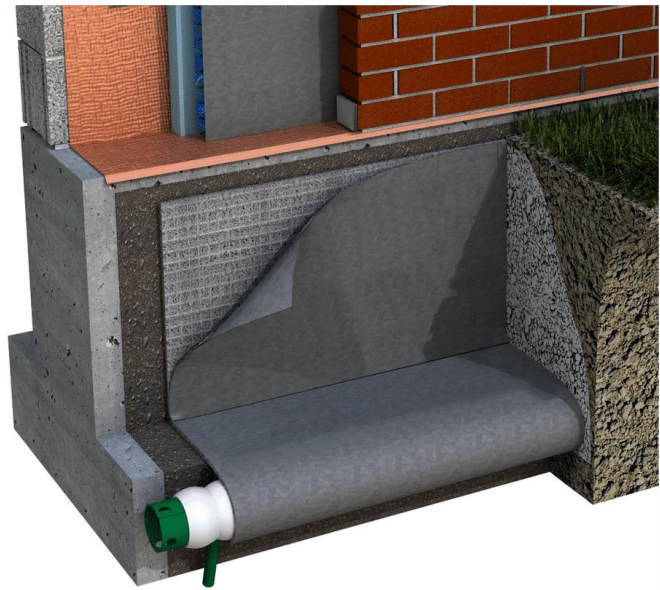
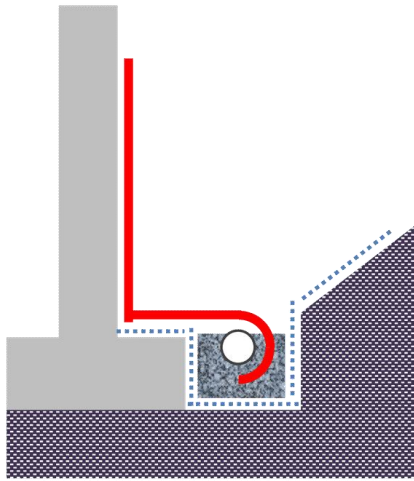

Installing Vertical Drainage Composite Panels (Mats)

Clean footing area of any debris.

Install water/damp proofing. Verify per the manufacturer's guidelines.

Snap a chalk line at finished grade.

Unroll drainage composite, cut (allow the length to wrap footing drainpipe), then place panel with the filter fabric toward the soil side.

Attach panel at chalk line with power-actuated fasteners to hold the panel in place.

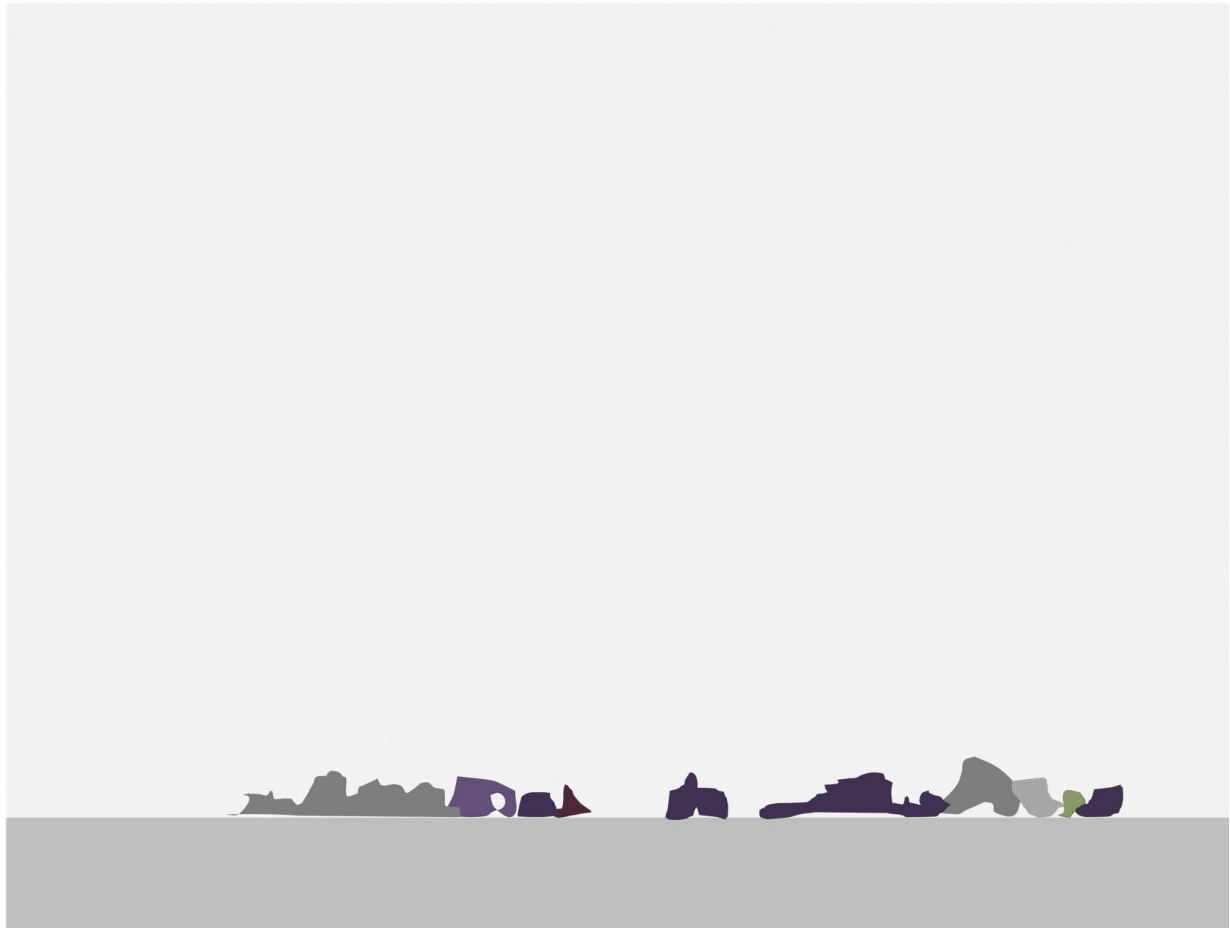

Clean footing area of any debris.

Install water/damp proofing. Verify per manufacturer's guidelines.

Snap a chalk line at finished grade.

Unroll drainage composite, cut (allow the length to wrap footing drainpipe), then place panel with the filter fabric toward the soil side.

Attach panel at chalk line with power-actuated fasteners to hold the panel in place.



Clean footing area of any debris.

Install water/damp proofing. Verify per manufacturer's guidelines.

Snap a chalk line at finished grade.

Unroll drainage composite, cut (allow the length to wrap footing drainpipe), then place panel with the filter fabric toward the soil side.

Attach panel at chalk line with power-actuated fasteners to hold the panel in place.

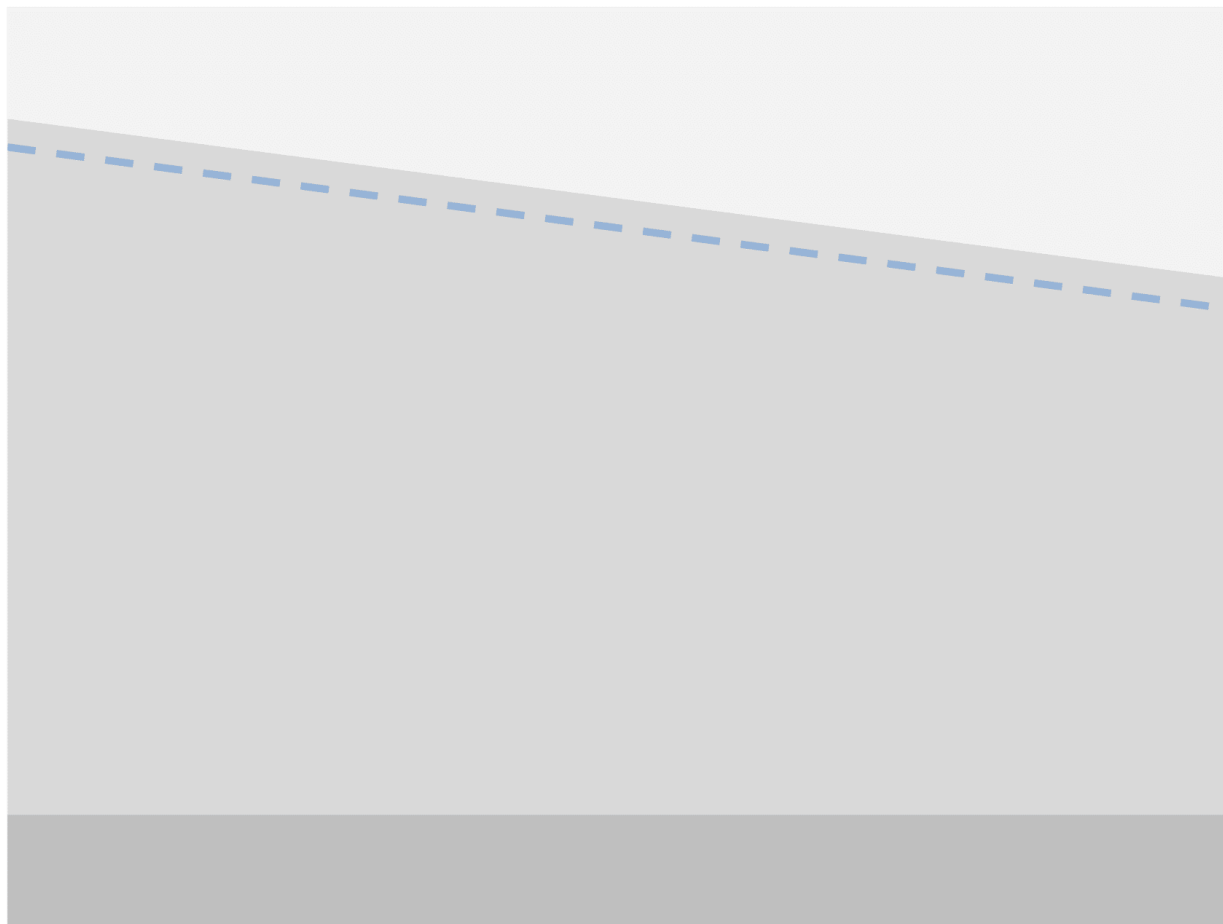

Clean footing area of any debris.

Install water/damp proofing. Verify per manufacturer's guidelines.

Snap a chalk line at finished grade.

Unroll drainage composite, cut (allow the length to wrap footing drainpipe), then place panel with the filter fabric toward the soil side.

Attach panel at chalk line with power-actuated fasteners to hold the panel in place.

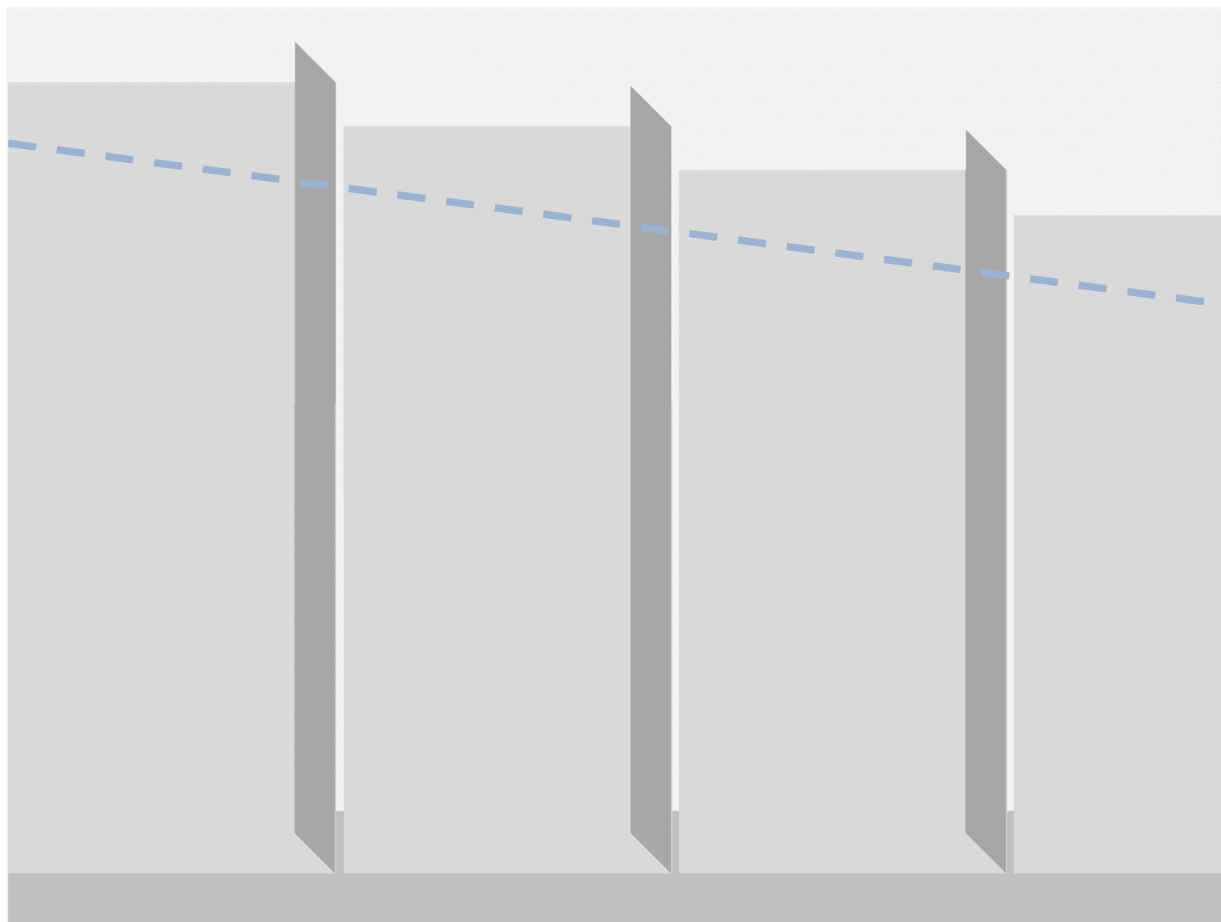

Clean footing area of any debris

Install water/damp proofing. Verify per manufacturer's guidelines.

Snap a chalk line at finished grade.

Unroll drainage composite, cut (allow the length to wrap footing drainpipe), then place panel with the filter fabric toward the soil side.

Attach panel at chalk line with powder-actuated fasteners to hold the panel in place.

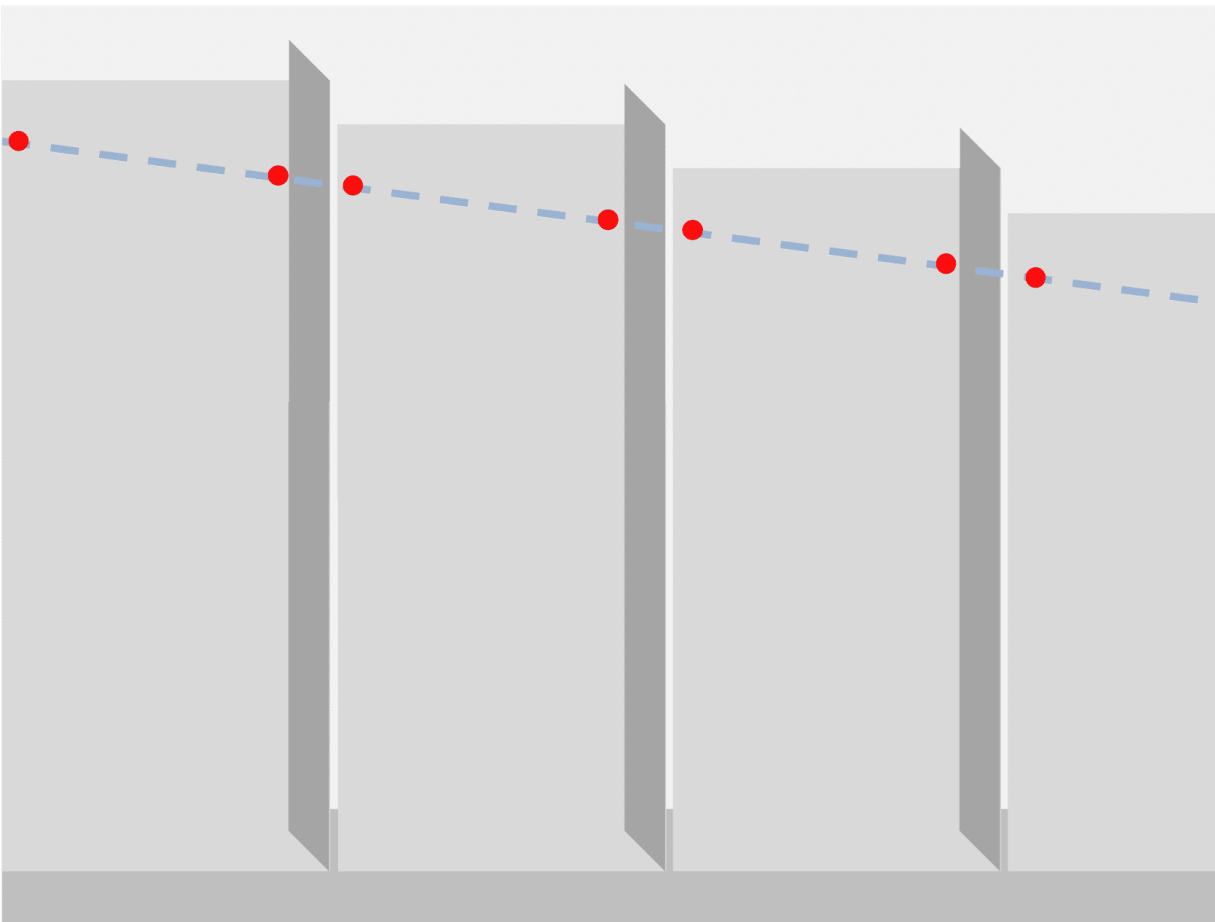

Fold flaps over and tack in place with construction adhesive, like liquid nails.

Install termination bar with sealant lip.

Trim excess drainage mat above the termination bar.

Apply sealant to termination bar lip.

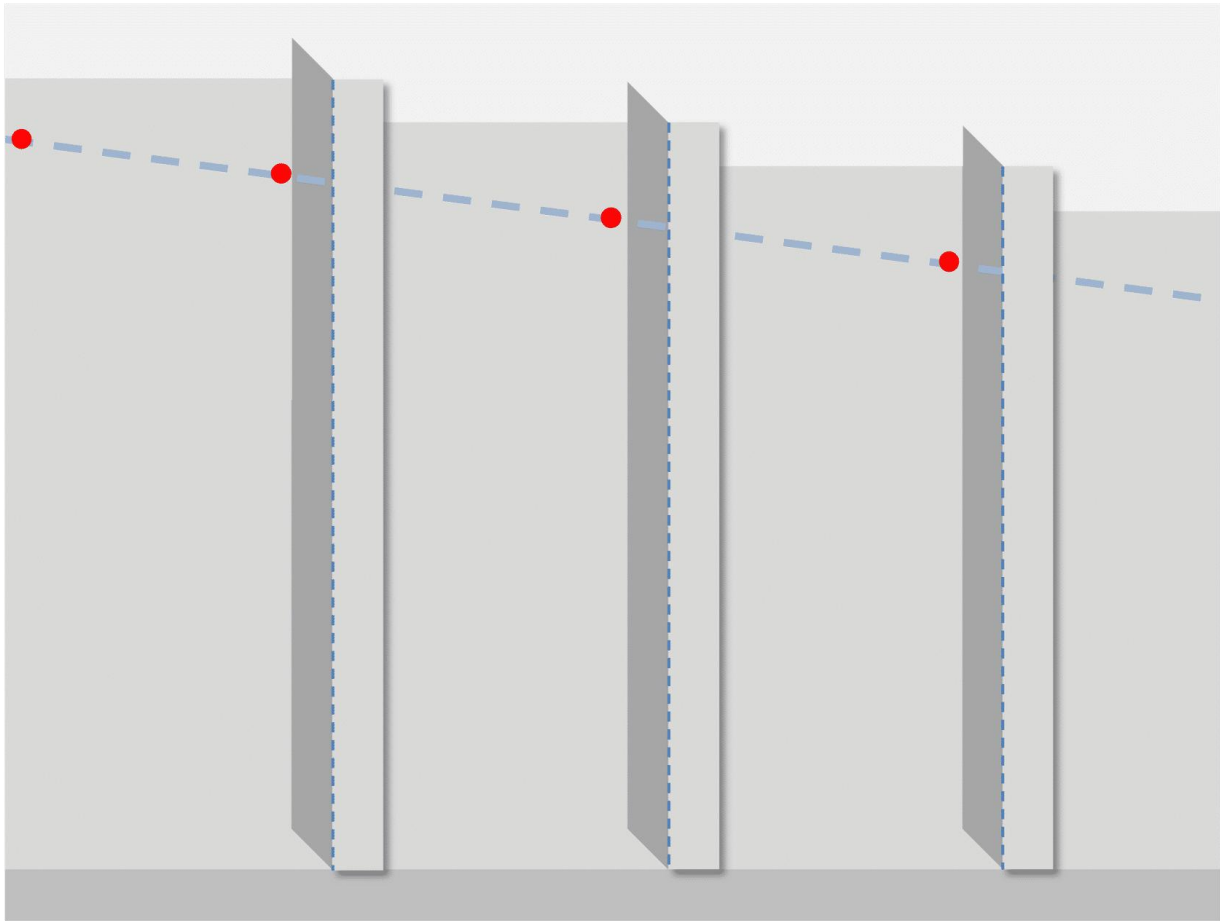

★ Please remember the password **HORIZONTAL**. You will need it to proceed with the online test.

Fold flaps over and tack in place with construction adhesive, like liquid nails.

Install termination bar with sealant lip.

Trim excess drainage mat above the termination bar.

Apply sealant to termination bar lip.

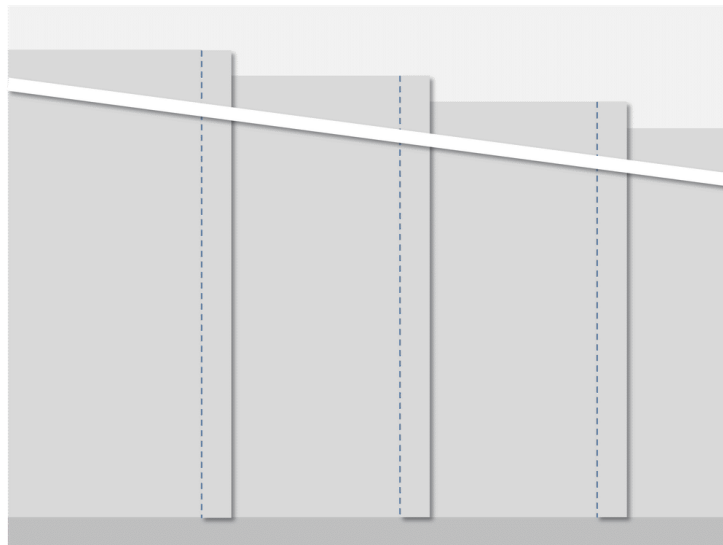
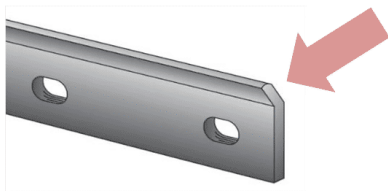

Fold flaps over and tack in place with construction adhesive, like liquid nails.
Install termination bar with sealant lip.
Trim excess drainage mat above the termination bar.
Apply sealant to termination bar lip.

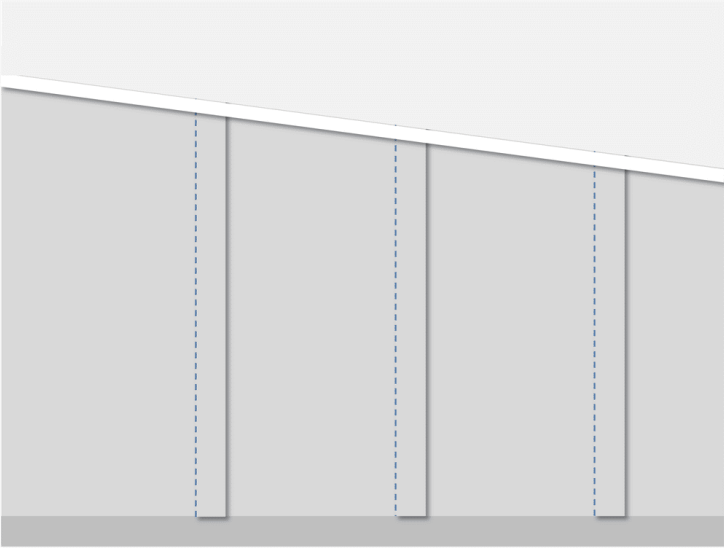

Fold flaps over and tack in place with construction adhesive, like liquid nails.
Install termination bar with sealant lip.
Trim excess drainage mat above the termination bar.
Apply sealant to termination bar lip.

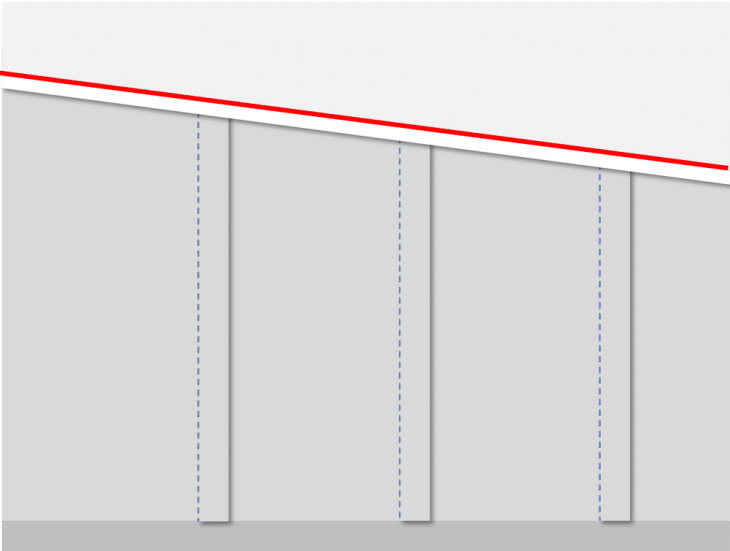

Be sure to notice that the height of the sheet drainage mat varies based on where the finish grade is planned to be.

After the drainage panels are installed, the extra length of the drainage composite mat should be wrapped around the drainpipe as shown in the drawing below. Finally, place gravel on top of the pipe in the drain mount, wrap the filter over the gravel, and then backfill the soil on that.

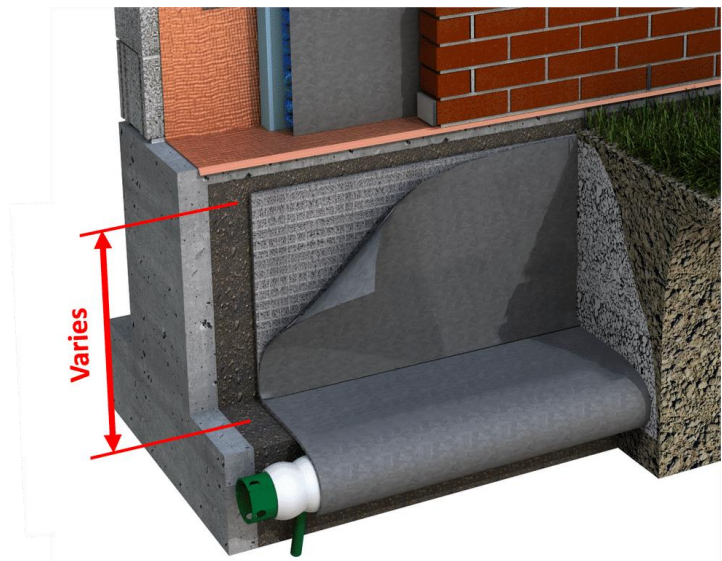
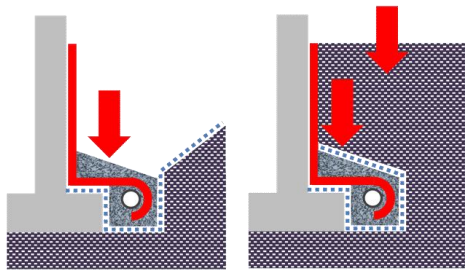

Thank You

Thank you for taking this course. If you desire AIA/CES, state licensing, or CE credits for another organization, please click on the button to commence your online test. A score of 80% or better will allow you to print your Certificate of Completion; you may also go to your AEC Daily Transcript to see your completed courses and certificates.



©2022 Advanced Building Products, Inc. The material contained in this course was researched, assembled, and produced by Advanced Building Products, Inc. and remains its property. Questions or concerns about the content of this course should be directed to the program instructor. This multimedia product is the copyright of AEC Daily.

Advanced Building Products, Inc.

Email: info@abp-1.com

Web: <https://www.advancedbuildingproducts.com>

TAKE THE TEST

[CLICK HERE](#)

QUESTIONS?

[ASK AN EXPERT](#)

